

# *Acta Medica Okayama*

---

*Volume 52, Issue 4*

1998

*Article 1*

AUGUST 1998

---

## Haptoglobin genotyping by allele-specific polymerase chain reaction amplification

Akemi Yano\*  
Satoru Miyaishi‡

Yuji Yamamoto†  
Hideo Ishizu\*\*

\*Okayama University,

†Okayama University,

‡Okayama Univeristy,

\*\*Okayama Uniiversity,

# Haptoglobin genotyping by allele-specific polymerase chain reaction amplification\*

Akemi Yano, Yuji Yamamoto, Satoru Miyaishi, and Hideo Ishizu

## Abstract

We performed haptoglobin (Hp) genotyping by polymerase chain reaction using allele-specific primer-pairs. The major six genotypes of Hp were identified using this method. Among Japanese individuals living in Ehime and Okayama Prefectures, the allele frequencies were estimated to be Hp2 = 0.723 and Hp1s = 0.277. Genotyping of Hp was possible with 0.3 ng of DNA and with 0.125 microliter of blood. It was also possible with whole blood left at room temperature for a month and also with the bloodstains left at room temperature for three years. In the heated blood samples, both alleles, Hp2 and Hp1s, were detected in those heated at 100 degrees C for 2 h. In bloodstains, Hp2 and Hp1s were detected in samples heated at 100 degrees C for 2 h and 120 degrees C for 30 min. In addition, the genotype could be detected in samples other than blood such as saliva, hair roots, tissue sections and dental pulps. The present method for Hp genotyping is expected to become a useful method in forensic analysis.

**KEYWORDS:** DNA polymorphism, haptoglobin, polymerase chain reaction, allele-specific amplification, personal identification

---

\*PMID: 9781267 [PubMed - indexed for MEDLINE]

Copyright (C) OKAYAMA UNIVERSITY MEDICAL SCHOOL

## Haptoglobin Genotyping by Allele-Specific Polymerase Chain Reaction Amplification

Akemi YANO, Yuji YAMAMOTO\*, Satoru MIYAISHI and Hideo ISHIZU

Department of Legal Medicine, Okayama University Medical School, Okayama 700-8558, Japan

We performed haptoglobin (Hp) genotyping by polymerase chain reaction using allele-specific primer-pairs. The major six genotypes of Hp were identified using this method. Among Japanese individuals living in Ehime and Okayama Prefectures, the allele frequencies were estimated to be  $Hp^2 = 0.723$  and  $Hp^{1S} = 0.277$ . Genotyping of Hp was possible with 0.3 ng of DNA and with 0.125  $\mu$ l of blood. It was also possible with whole blood left at room temperature for a month and also with the bloodstains left at room temperature for three years. In the heated blood samples, both alleles,  $Hp^2$  and  $Hp^{1S}$ , were detected in those heated at 100°C for 2 h. In bloodstains,  $Hp^2$  and  $Hp^{1S}$  were detected in samples heated at 100°C for 2 h and 120°C for 30 min. In addition, the genotype could be detected in samples other than blood such as saliva, hair roots, tissue sections and dental pulps. The present method for Hp genotyping is expected to become a useful method in forensic analysis.

**Key words:** DNA polymorphism, haptoglobin, polymerase chain reaction, allele-specific amplification, personal identification

**H**aptoglobin (Hp) is a serum glycoprotein discovered by Polonovski and Jayle (1), and it specifically binds to free hemoglobin in the plasma. Smithies found three major phenotypes of Hp, Hp 1-1, Hp 2-1, and Hp 2-2, by electrophoresis on starch gels (2). Smithies and Walker showed that these phenotypes are controlled by two autosomal alleles,  $Hp^1$  and  $Hp^2$  (3). Connell *et al.* and Smithies *et al.* showed that Hp 1 can be further divided into two subtypes, Hp 1S and Hp 1F, by electrophoresis on starch gels containing urea (4, 5). The Hp molecule has a tetrameric structure similar to that of

immunoglobulin (6), consisting of two  $\alpha$  and two  $\beta$  chains linked with S-S bonds between  $\alpha$  and  $\beta$  chains and between the two  $\alpha$  chains. The  $\beta$  chain consisting of 245 amino acids shows no genetic polymorphism. On the other hand, the  $\alpha$  chain shows genetic polymorphism:  $\alpha_1$  consists of 83 amino acids and  $\alpha_2$  consists of 142 amino acids. The  $\alpha_1$  is further divided into  $\alpha_1S$  and  $\alpha_1F$ . The  $\alpha_1S$  chain differs from the  $\alpha_1F$  chain in that the 52nd and 53rd amino acids from the N terminal are asparagine and glutamic acid, respectively, in the former, and aspartic acid and lysine, respectively, in the latter. The  $\alpha_2$  chain ( $\alpha_2FS$  chain) is considered to be formed by insertion of the 11th to the 69th amino acids of the  $\alpha_1F$  chain into the  $\alpha_1S$  chain, and duplication is partially observed. Three major alleles,  $Hp^{1S}$ ,  $Hp^{1F}$  and  $Hp^2$ , control the expression of these polypeptide chains, and there are six major subtypes of serum Hp, Hp 1S-1S, Hp 1F-1S, Hp 1F-1F, Hp 2-1S, Hp 2-1F and Hp 2-2. However, Hp serotyping is usually limited to the three major phenotypes, and subtyping is not performed in routine examinations because the technique is complicated.

The genomic nucleotide sequence of  $Hp^2$ , a partial genomic sequence of  $Hp^{1F}$  and a sequence of cDNA encoding  $Hp^{1S}$  were reported by Maeda *et al.*, Bensi *et al.* and Straten *et al.*, respectively (7-9). The base substitution sites corresponding to the polymorphic sites on the  $Hp\alpha_1S$  and  $Hp\alpha_1F$  polypeptide chains are present at exon 4 of  $Hp^{1S}$  and  $Hp^{1F}$ , where two synonymous substitutions and two base substitutions which cause changes in two amino acids are observed between the two Hp alleles.  $Hp^2$  is considered to be formed by insertion of about 2 kb of homologous residues derived from  $Hp^{1F}$  into the 3' terminal region of exon 2 in  $Hp^{1S}$  by an unequal crossing-over in a heterozygous genotype  $Hp^{1F}/Hp^{1S}$  (7), so that homologous residues containing each

\*To whom correspondence should be addressed.

specific nucleotide sequence of *Hp*<sup>1F</sup> and *Hp*<sup>1S</sup> are repeated in tandem in *Hp*<sup>2</sup>. In this study, we performed *Hp* genotyping by allele-specific polymerase chain reaction (PCR), focusing on base substitution and insertion sites of nucleotide sequences of *Hp* alleles.

## Materials and Methods

**Materials.** Peripheral blood samples from 148 Japanese subjects living in Ehime and Okayama Prefectures were used for a population study and other forensic experiments. Lymphocytes were isolated from 3 to 5 ml of the peripheral blood using a Ficoll plaque (Pharmacia Biotech, Uppsala, Sweden), and buffy coats were obtained from 5 ml of whole blood by differential sedimentation using 3.5 % dextran. One milliliter of whole blood was kept in sealed test tubes at room temperature. After three days to one month, 20  $\mu$ l each of the sample was collected. Bloodstains were made on cotton cloths using 5  $\mu$ l of whole blood and kept at room temperature for 10 days to three years. Twenty microliters of the whole blood samples were placed in tubes and were heated in a water bath at 50, 60, 80 or 100 °C for 1, 2 or 4 h. Bloodstains were made on cotton cloths using 20  $\mu$ l of whole blood and heated in an electric furnace at 100, 120, 150 or 200 °C for 0.5, 1 or 2 h. Other samples used included five samples of 1.5 cm<sup>2</sup> bloodstain which had been stored for 20 years at room temperature and three samples each taken from the following materials: sediments from 500  $\mu$ l saliva after centrifugation; kidney and muscle sections (8 mm<sup>3</sup>) obtained from autopsies; a 5 mm root portion of two or three plucked hairs; and the dental pulp of extracted teeth. DNA extracted from blood samples of 20 German subjects provided by Dr. Isao Yuasa of Tottori University was also used.

**DNA extraction.** To the lymphocyte pellets, 100–300  $\mu$ l of lysis buffer (10 mM Tris-HCl, pH 8.0, 0.1 mM EDTA, 50 mM NaCl, 2 % SDS, 200  $\mu$ g/ml Proteinase K) was added. To the buffy coats, the whole blood kept at room temperature and the heated whole blood, 0.5 ml of lysis buffer was added. To the bloodstains kept at room temperature and the heated bloodstains, 0.6 ml of lysis buffer was added. To the saliva sediments, tissue pieces, hair roots and dental pulps, 0.5 ml of lysis buffer was added. Each mixture was heated at 56 °C for 1 to 5 h, soaked in boiling water for 5 min, and extracted three times with phenol/chloroform/isoamyl alcohol (25:24:1). DNA was precipitated with sodium

**Table 1** Nucleotide sequences of the primers used for the present study

Primer	Oligonucleotide sequence (5'-3')
F3	CAGGAGTATACACCTTAAATG
S2	TTATCCACTGCTTCTCATTG
C42	TTACTACTGGTAGCGAACCGA
C72	AATTTAAAATTGGCATTTCGCC
C51	GCAATGATGTCACGGATATC

**Table 2** Primer sets for polymerase chain reaction

Reactions	Primer sets	Target alleles	Predicted size (bp)
Reaction 2	F3-C42	<i>Hp</i> <sup>2</sup>	935
Reaction S	C51-S2	<i>Hp</i> <sup>1S</sup>	1.2 k
Reaction F	F3-C72	<i>Hp</i> <sup>1F</sup>	1.4 k

bp: Base pair

acetate and isopropyl alcohol and dissolved in TE buffer (10 mM Tris-HCl, 1 mM EDTA, pH 8.0). The concentrations of the extracted DNA were measured spectrophotometrically at 260 nm using a Beckman DU-63 spectrophotometer (Beckman Instruments, Fullerton, CA, USA).

**Primers.** Table 1 shows the sequences of newly designed primers for the *Hp* genotyping. Table 2 shows the combinations of the primers and predicted sizes of DNA fragments amplified in each reaction. Fig. 1 shows the gene structure of *Hp*, the predicted annealing sites of the primers, and restriction sites (7–9). Primers C51 and S2 were used in Reaction S, and this combination amplified 1.2 kb DNA fragments. In Reaction F, primers F3 and C72 were used, and this combination amplified 1.4 kb DNA fragments. In Reaction 2, primers F3 and C42 were used, which amplified 935 bp DNA fragments.

**PCR.** PCR was performed in a 25  $\mu$ l reaction mixture consisting of 10 mM Tris-HCl (pH 9.0), 50 mM KCl, 0.1 % Triton X-100, 2.5 mM MgCl<sub>2</sub>, 200  $\mu$ M of each dNTP, 1.5 units of Taq DNA polymerase (AmpliTaq<sup>R</sup> DNA polymerase, Perkin-Elmer, Branchburg, NJ, USA.), and 0.2  $\mu$ M of each primer with 1  $\mu$ l of each sample. After preheating at 95 °C for 3 min, PCR was performed with 35 cycles of heating at 94 °C for 40 sec, at 58 °C for 1 min, and at 72 °C for 2 min.

**Electrophoresis.** PCR products were electrophoresed at 50 V for 1 h on 1.2 % agarose gels and stained with ethidium bromide (EtBr), and the *Hp* geno-

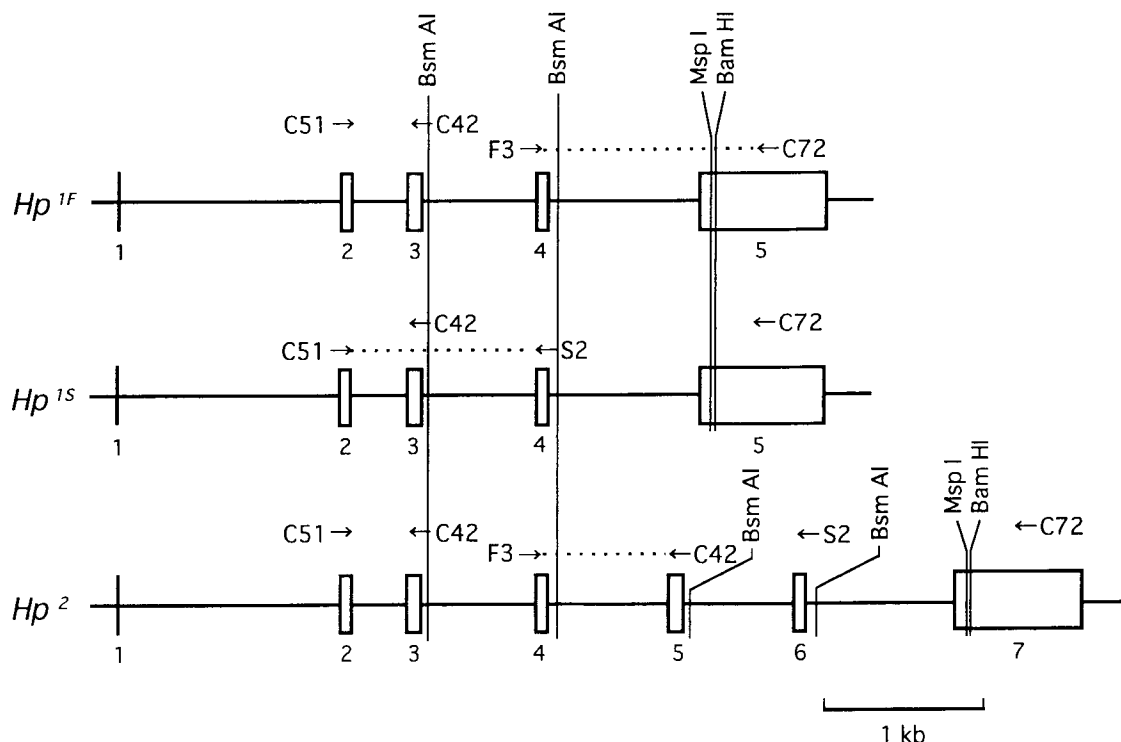

Fig. 1 Schematic presentation of the genomic structure of human haptoglobin (*Hp*). The box indicates the exon, and the figure under the box indicates the exon number. The predicted annealing sites of the primers are shown by the arrows. The dotted line indicates the fragments to be amplified by the present method. The restriction sites are also shown.

types were determined by observing the amplified DNA fragments under ultraviolet light.

**Sensitivity.** Peripheral blood of the two subjects whose *Hp* genotypes had been determined to be *Hp*<sup>2</sup>-*Hp*<sup>1S</sup> was diluted 1/5–1/160. DNA was extracted from 5  $\mu$ l of the dilutions and dissolved in 20  $\mu$ l of TE. Detection of *Hp*<sup>2</sup> and *Hp*<sup>1S</sup> in 3  $\mu$ l of each DNA solution was attempted by PCR. DNA extracted from peripheral blood lymphocytes of a *Hp*<sup>2</sup>-*Hp*<sup>1S</sup> subject was adjusted to 100  $\mu$ g/ml and diluted to 10<sup>1</sup>–10<sup>6</sup>. Detection of *Hp*<sup>2</sup> and *Hp*<sup>1S</sup> in 1  $\mu$ l of the dilutions was attempted by PCR.

**Restriction enzyme analysis of the PCR products.** Each PCR product amplified using one of the three allele-specific primer combinations was digested

with three restriction enzymes, BsmAI, BamHI and MspI. According to the instructions, 2  $\mu$ l of each PCR product was digested with 5 units of each enzyme at 37  $^{\circ}$ C for 3 h and electrophoresed at 50 V for one hour on a 1.2% agarose gel. After EtBr staining, the digested products were observed under ultraviolet light. Predicted restriction sites of the enzymes were shown in Fig. 1.

***Hp* subtyping by isoelectric focusing.** *Hp* subtypes were determined by isoelectric focusing according to the method of Shibata *et al.* (10). *Hp* molecules were purified from each serum sample using 1% DEAE cellulose, and *Hp* polypeptides were obtained by reduction with urea and 2-mercaptoethanol. These polypeptides were separated by isoelectric focusing of Teige *et al.* (11) and detected by immunostaining with an anti-human *Hp* sheep antibody IgG fraction (Binding Site, Birmingham, UK), peroxidase-labeled anti-sheep IgG (Organon Teknika, West Chester, PA, USA), and a Diaminobentidine kit (Zymed Laboratories, San Francisco, CA, USA).

## Results

***Hp* genotyping.** Fig. 2 shows the result of *Hp* genotyping by PCR in DNA extracted from six subjects with each of six subtypes which had been preliminarily determined by isoelectric focusing. Observing the presence or absence of the target DNA fragments in each reaction, the genotypes of these samples were determined

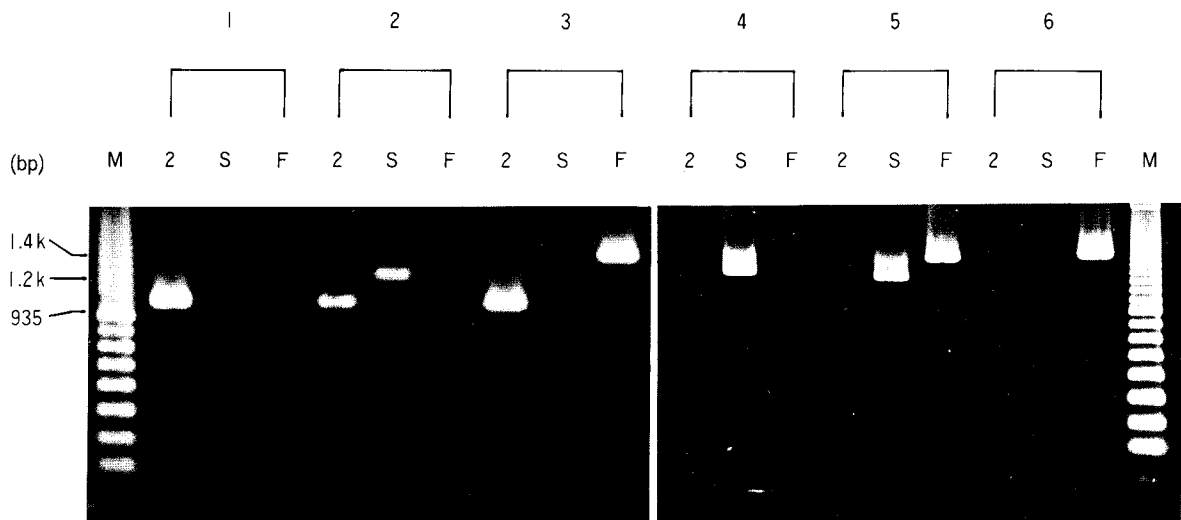

**Fig. 2** Haptoglobin (Hp) genotyping from six individuals with known Hp serotypes by the present method.

1: Hp 2-2; 2: Hp 2-1S; 3: Hp 2-1F; 4: Hp 1S-1S; 5: Hp 1F-1S; 6: Hp 1F-1F.

Lane 2: Polymerase chain reaction (PCR) products in reaction 2; Lane S: PCR products in reaction S; Lane F: PCR products in reaction F. M: 100bp ladder DNA marker.

**Fig. 3** Restriction enzyme analysis of the polymerase chain reaction (PCR) products.

2: PCR products in reaction 2; S: PCR products in reaction S; F: PCR products in reaction F.

U: Undigested; A: Digested with BsmAI; H: Digested with BamHI; P: Digested with MspI.

M: 100bp ladder DNA marker.

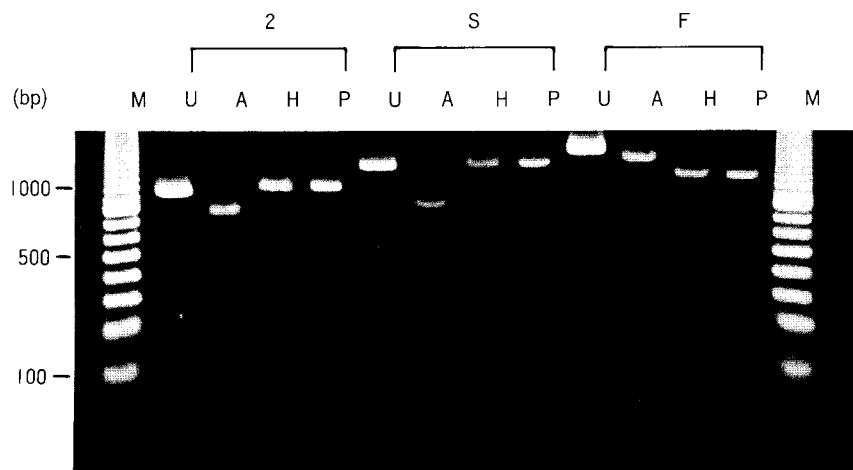

as  $Hp^2-Hp^2$ ,  $Hp^2-Hp^{1S}$ ,  $Hp^2-Hp^{1F}$ ,  $Hp^{1S}-Hp^{1S}$ ,  $Hp^{1F}-Hp^{1S}$  and  $Hp^{1F}-Hp^{1F}$ , respectively, and these genotypes were consistent with the subtypes preliminarily determined.

**Restriction enzyme analysis of the PCR products.** Restriction enzyme analysis of the PCR products in each sample of six genotypes determined by PCR was performed with BsmAI, BamHI and MspI (Fig. 3). Each of the amplified product of  $Hp^2$ ,  $Hp^{1S}$  and

**Table 3** Distribution of Hp genotypes in Japanese

Genotypes	Numbers observed (%)	Numbers expected
$Hp^2-Hp^2$	75 (50.7)	77.4
$Hp^2-Hp^{1S}$	64 (43.2)	59.2
$Hp^{1S}-Hp^{1S}$	9 (6.1)	11.4
Total	148 (100.0)	148.0

August 1998

Hp Genotyping by Allele-Specific PCR 177

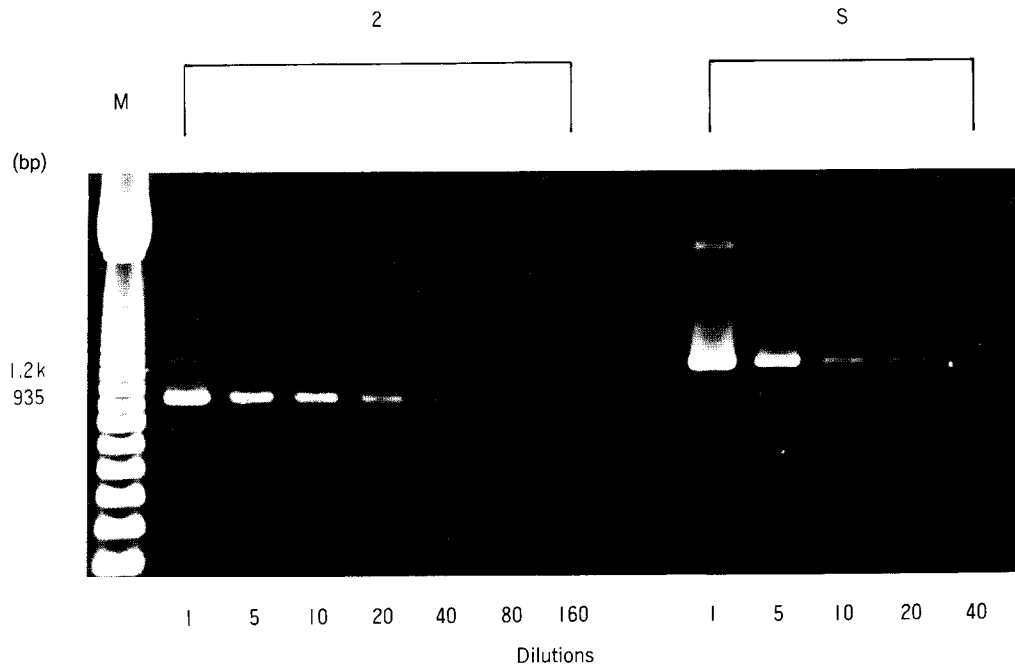

**Fig. 4** Haptoglobin (Hp) genotyping from diluted blood.  
 2: polymerase chain reaction (PCR) products in reaction 2 of a  $Hp^2-Hp^{1S}$  sample; S: PCR products in reaction S of a  $Hp^2-Hp^{1S}$  sample.  
 M: 100bp ladder DNA marker.

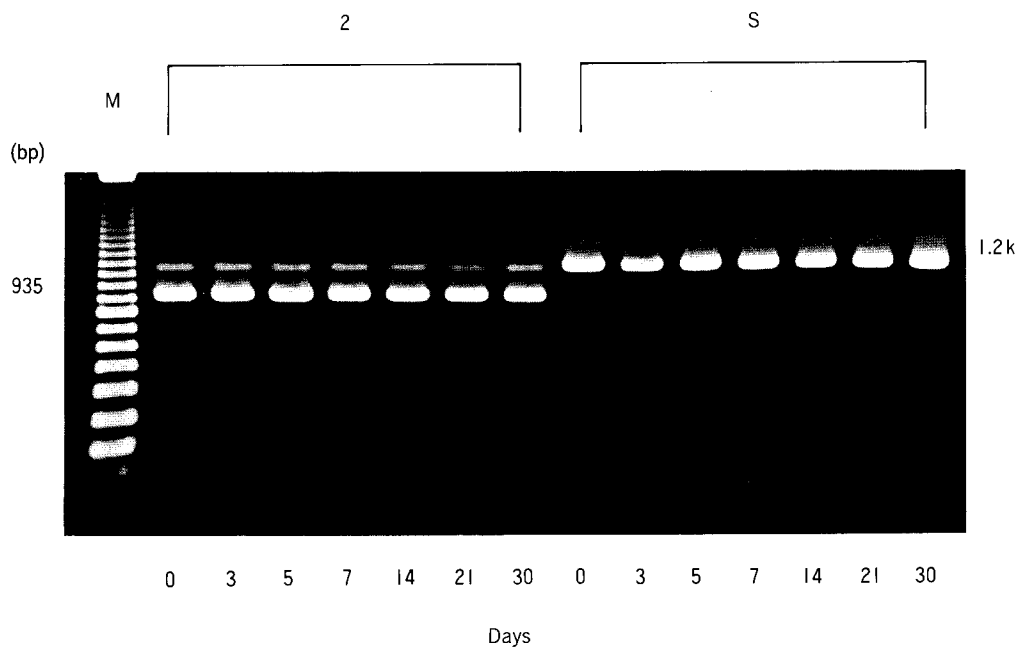

**Fig. 5** Haptoglobin (Hp) genotyping from blood stored at room temperature.  
 See legend to Fig. 4.

$Hp^{1F}$  was cut at a unique site by BsmAI and predicted fragments were obtained. The amplified  $Hp^{1F}$  products were cut by BamHI and MspI, but neither  $Hp^2$  nor  $Hp^{1S}$  products were cut by these two enzymes.

#### **Distribution of Hp genotypes in Japan.**

Table 3 shows Hp genotypes in 148 Japanese males and females living in Ehime and Okayama Prefectures. The allele frequencies were estimated to be  $Hp^2 = 0.723$  and  $Hp^{1S} = 0.277$ . These results agreed with Hardy-Weinberg equilibrium in the  $\chi^2$  test ( $\chi^2 = 0.9687$ , d. f. = 1,  $p = 0.616$ ). The serotypes of 100 of these samples as determined by polyacrylamide gel disc electrophoresis were consistent with the genotypes determined by the present method. None of these 148 Japanese subjects had  $Hp^{1F}$ . However, in 20 German subjects, two  $Hp^2$ - $Hp^{1F}$ , five  $Hp^{1S}$ - $Hp^{1F}$  and one  $Hp^{1F}$ - $Hp^{1F}$  subjects were observed.

**Sensitivity of the present method.** Hp genotyping was possible with  $5\mu\text{l}$  of 40-fold diluted blood samples (equivalent to  $0.125\mu\text{l}$  whole blood) obtained from two  $Hp^2$ - $Hp^{1S}$  subjects (Fig. 4). Genotyping of  $Hp^2$ - $Hp^{1S}$  was possible with  $10^3$ -fold dilutions of  $100\mu\text{g}/\text{ml}$  DNA samples (0.3ng DNA).

#### **Hp genotyping from blood and bloodstains.**

Blood samples of five subjects with  $Hp^2$ - $Hp^{1S}$  genotype

preliminarily determined from lymphocyte DNA were examined for  $Hp^2$  and  $Hp^{1S}$  after storage at room temperature. Clear bands were obtained from both alleles in the blood kept for as long as a month, and the genotype could be determined (Fig. 5).

In bloodstains prepared from blood samples of five subjects with  $Hp^2$ - $Hp^{1S}$  and left at room temperature, both alleles were detected even after three years, and the genotype could be determined (Fig. 6). Hp genotyping was possible in one of five bloodstains that had been kept for 20 years.

#### **Hp genotyping of heated blood and bloodstains.**

To examine the effects of heating on Hp genotyping, blood samples of two subjects with  $Hp^2$ - $Hp^{1S}$  were heated at 50–100°C for 1–4h, and detection of  $Hp^2$  and  $Hp^{1S}$  was attempted. Both alleles were detected in the samples heated at 50, 60 and 80°C for 4 h. In the samples heated at 100°C, both alleles were detected after 1 or 2h, but not after 4h. In bloodstains from two subjects with  $Hp^2$ - $Hp^{1S}$  heated at 100–200°C for 30min to 2h,  $Hp^{1S}$  was detected in the samples heated for 2h at 100°C and 30min at 120°C, and  $Hp^2$  was detected in the samples heated for 2h at 100 and 120°C. Neither of the alleles were detected in samples heated to 150°C or higher.

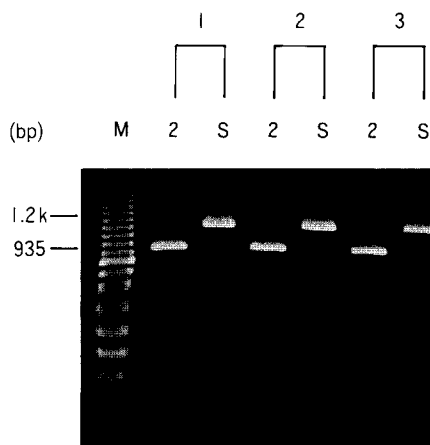

**Fig. 6** Haptoglobin (Hp) genotyping from three bloodstains of  $Hp^2$ - $Hp^{1S}$  stored at room temperature for three years.

Lane 2: Polymerase chain reaction (PCR) products in reaction 2; Lane S: PCR products in reaction S.

M: 100bp ladder DNA marker.

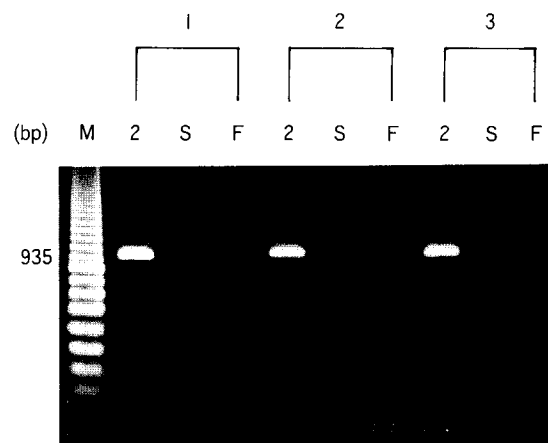

**Fig. 7** Haptoglobin (Hp) genotyping from different parts of the same subject.

1: Blood; 2: Kidney; 3: Muscle.

Lane 2: Polymerase chain reaction (PCR) products in reaction 2; Lane S: PCR products in reaction S; Lane F: PCR products in reaction F.

M: 100bp ladder DNA marker.



***Hp genotyping of samples other than blood.*** Hp genotyping of DNA extracted by the present method from other samples, *i.e.* saliva sediments, hair roots, dental pulps, kidney and muscle sections, showed the same Hp genotypes as determined from blood collected from the same subjects (Fig. 7).

## Discussion

Hp serotyping is usually limited to determining the three major phenotypes by polyacrylamide gel disc electrophoresis and subtyping is not performed in routine examinations due to its complicated procedure. Hp genotyping methods at the DNA level such as the Southern blot methods have been reported by Hill *et al.*, David *et al.* and Yokoi and Sagisaka (12-14). In the present study, we focused on the presence of polymorphic sites in the Hp  $\alpha$  chains and performed Hp genotyping by allele-specific PCR.

DNA samples extracted from lymphocytes were subjected to PCR using the three allele-specific primer-pairs for detection of  $Hp^2$ ,  $Hp^{1S}$ ,  $Hp^{1F}$  and DNA fragments were successfully amplified by the corresponding primer combinations. It was difficult to establish an allele-specific primer-pair for detection of  $Hp^2$  alone because nucleotide sequences similar to those of  $Hp^{1S}$  and  $Hp^{1F}$  were present in  $Hp^2$  due to an unequal crossing-over. However, we noted that exon 3 derived from  $Hp^{1S}$  is present in exon 5 of  $Hp^2$  and succeeded in detecting the 935bp DNA fragment specific to  $Hp^2$  using the combination of primer F3 with an annealing site on exon 4 of  $Hp^2$  and primer C42 with an annealing site on exon 5 of  $Hp^2$ . In  $Hp^2$ , an annealing site of primer C42 was also present on exon 3, but corresponding DNA fragments were not amplified because its direction was not adequate for working with primer F3. Since the primer-pair C51 and S2, allele-specific to  $Hp^{1S}$ , and the primer-pair F3 and C72, allele-specific to  $Hp^{1F}$ , have annealing sites also on  $Hp^2$ , amplification of DNA fragments of about 3kb and 2.5kb in  $Hp^2$  were predicted in reaction S and in reaction F, respectively. However, such fragments were not amplified because the fragments are large and hard to amplify compared with the target DNA fragments of the primers. Since the nucleotide sequence of the Hp related gene (*Hpr*), which is similar to that of the Hp gene, is present in 2.2kb downstream of the Hp locus, primers C42, C72 and C51 were designed so that nucleotide sequences of *Hpr* would not be amplified. The results of restriction

enzyme analysis of the PCR products and the strict correspondence between the genotypes determined by this method and the phenotypes determined by the conventional serotyping method in 100 subjects strongly suggest that Hp alleles were correctly detected by the present method.

Hp genotyping of the 148 Japanese subjects by the present method showed allele frequencies of  $Hp^2 = 0.723$  and  $Hp^{1S} = 0.277$ . Hp serotyping of 600 subjects living in Okayama Prefecture by disc electrophoresis showed allele frequencies of  $Hp^1 = 0.264$  and  $Hp^2 = 0.740$  (15), and that of 164 subjects living in Ehime Prefecture by immunoelectrophoresis showed allele frequencies of  $Hp^1 = 0.268$  and  $Hp^2 = 0.732$  (16). The allele frequencies of both studies are similar to the average distribution of the allele frequency in the entire Japanese population (17), and there were no significant differences between those results and the present result ( $\chi^2 = 0.3827$ , d. f. = 2,  $P = 0.825$ ). In the present study,  $Hp^{1F}$  was not observed in the 148 Japanese subjects, but it was detected in eight of the 20 German subjects. There are differences in the incidence of Hp genes between races, and the  $Hp^{1F}$  is known to be higher in Caucasians and Africans than in Mongolians including Japanese. The incidence of  $Hp^{1F}$  is 0.12-0.16 in Caucasians, while it is very rare in Mongolians, and it was reported to be 0.0014-0.0085 in Japanese (18-21).

Conventionally, polyacrylamide gel disc electrophoresis has been used for Hp serotyping, for which about 10  $\mu$ l of serum is required. A larger amount of serum is usually required for subtyping by isoelectric focusing. In the Southern blot method for Hp genotyping, 0.5  $\mu$ g DNA was used (14). On the other hand, Hp genotyping by the present method requires only very small volumes of blood, that is 0.125  $\mu$ l, or 0.3ng of extracted DNA. In addition, unlike conventional serological methods, the genotypes could be determined from samples other than blood. There have been a number of studies on the sensitivity of detection of single copy genes by PCR. Kojima *et al.* detected the HLA-DPB1 gene from 100pg of DNA (22), and Comey and Budowle detected the HLA-DQA1 gene from 0.065ng DNA (23). The minimum amount for detection of MCT118 was reported to be 0.03-0.06ng by Watanabe *et al.* (24), and 0.1ng by Kloosterman *et al.* (25). Wiegand *et al.* detected microsatellite TC11 (TH01) and SE33 (ACTBP2) from 50 pg of DNA (26). Although target DNA fragments are relatively large, about 1kb, the present method of Hp

genotyping is considered to have a relatively high sensitivity.

Genotyping was attempted using blood samples that had been kept for extended periods at room temperature. Since DNA is degraded in putrefied blood, genotyping of samples kept for a long period was thought to be difficult by the present method. However, clear bands were observed even in blood samples kept at room temperature for one month, and Hp genotypes were easily determined without smears and additional bands on electrophoresis. These results showed that DNA molecules of about 1 kb, which can serve as a template for PCR amplification, even remain in putrefied blood kept at room temperature for one month. If the blood samples had dried out during storage, putrefaction might have stopped, and decomposition of DNA would have been delayed. Since the test tubes containing the samples were sealed in this study, desiccation is unlikely to have affected the results.

Bloodstains are often important evidence materials in forensic practice, and Hp serotyping of bloodstains have been attempted, however, it is difficult due to excess hemoglobin, and methods to circumvent this problem have been developed (27-31). DNA molecules in bloodstains are stable for long periods, and detection of DNA polymorphisms in old bloodstains has been reported. Kasai *et al.* showed that MCT118 was detected in bloodstains left for five years (32), and TH01 in bloodstains left for 20 years (33). TH01 and other five STR loci were detected in bloodstains left for 10 to 13 years (34). Takata *et al.* detected IgA2 genotypes in bloodstains left for 20 years (35). In the present study, Hp genotypes were easily determined from bloodstains kept for three years, and Hp genotyping was successful even in bloodstains kept for 20 years.

Since Hp genotyping of heated samples is sometimes required, the effects of heating on Hp genotyping of blood and bloodstains were examined. Hp genotypes could be detected in the whole blood heated for 2 h at 100°C, suggesting that Hp genes are markedly stable upon heating to 100°C. Azumi *et al.* attempted to detect MCT118 in heated blood samples and reported that its detection was possible in samples heated for 2 h at 100°C (36). DNA in dried bloodstains was more resistant to heating. Detection of both  $Hp^2$  and  $Hp^{15}$  was possible in the samples heated at 120°C for up to 30 min.  $Hp^2$  was further detected in samples heated at 120°C for 2 h, showing its higher resistance to heating than  $Hp^{15}$ . This may be because the target DNA fragment of  $Hp^{15}$  was

larger than that of  $Hp^2$ . Azumi *et al.* examined the influence of heating temperature and time on detection of DNA fragments by PCR, and reported that detection of a 203 bp fragment of the SRY gene was possible with samples heated for up to 2 h at 150°C, and detection of a 371-787 bp fragment of MCT118 was possible with samples heated for up to 1 h at 150°C, showing that smaller DNA fragments could be detected in samples heated for longer periods (36). Since the target DNA in this study was larger than these genes, it was considered that its detection was no longer possible after heating for shorter periods.

The simple method of identifying Hp genotypes by PCR, is relatively sensitive and can achieve Hp genotyping not only from aged blood and bloodstains, but also from samples other than blood, unlike conventional serological methods. Therefore, it is expected to become a useful testing method for practical work in forensic medicine.

**Acknowledgments.** We acknowledge Dr. Isao Yuasa for providing us the DNA samples from 20 German subjects. This work was supported in part by a Grant-in-Aid (No. 06454247) for Scientific Research from the Ministry of Education, Science, Sports, and Culture, Japan.

## References

1. Polonovski M and Jayle MF: Peroxydases animales, Leur spécificité et leur rôle biologique. Bulletin de la Societe de chemie biologique (1938) **21**, 66-91.
2. Smithies O: Zone electrophoresis in starch gels: Group variations in the serum proteins of normal human adults. Biochem J (1955) **61**, 629-641.
3. Smithies O and Walker NF: Notation for serum-protein groups and the genes controlling their inheritance. Nature (1956) **178**, 694-695.
4. Connell GE, Dixon GH and Smithies O: Subdivision of the three common haptoglobin types based on 'hidden' differences. Nature (1962) **193**, 505-506.
5. Smithies O, Connell GE and Dixon GH: Inheritance of haptoglobin subtypes. Am J Hum Genet (1962) **14**, 14-21.
6. Bowman BH and Kurosky A: Haptoglobin: The evolutionary product of duplication, unequal crossing over, and point mutation. Adv Hum Genet (1982) **12**, 189-261.
7. Maeda N, Yang F, Barnett DR, Bowman BH and Smithies O: Duplication within the haptoglobin  $Hp^2$  gene. Nature (1984) **309**, 131-135.
8. Bensi G, Raugeri G, Klefenz H and Cortese R: Structure and expression of the human haptoglobin locus. EMBO J (1985) **4**, 119-126.
9. Straten A, Herzog A, Cabezón T and Bollen A: Characterization of human haptoglobin cDNAs coding for  $\alpha^{2F5} \beta$  and  $\alpha^{15} \beta$  variants. FEBS Lett (1984) **168**, 103-107.
10. Shibata K, Constans J, Viau M and Matsumoto H: Polymorphism of the haptoglobin peptides by isoelectric focusing electrophoresis and isoelectric point determinations. Hum Genet (1982) **61**, 210-214.
11. Teige B, Olaisen B and Pederson L: Subtyping of haptoglobin-Presentation of a new method. Hum Genet (1985) **70**, 163-167.

12. Hill AVS, Bowden DK, Flint J, Whitehouse DB, Hopkinson DA, Oppenheimer SJ, Serjeantson SW and Clegg JB: A population genetic survey of the haptoglobin polymorphism in Melanesians by DNA analysis. *Am J Hum Genet* (1986) **38**, 382-389.
13. David F, Lavadera S and Lucotte G: Electrophoretic detection of the haptoglobin polymorphism at the DNA level. *Electrophoresis* (1986) **7**, 570-572.
14. Yokoi T and Sagisaka K: Haptoglobin typing of human bloodstains using a specific DNA probe. *Forensic Sci Int* (1990) **45**, 39-46.
15. Ishizu H: The distribution of haptoglobin types in Okayama district. *Okayama Igakkai Zasshi* (1977) **89**, 721-724 (in Japanese).
16. Shinomiya K, Shinomiya T and Kimura H: Essai de détermination simultanée du type haptoglobinique et du type d' $\alpha^2$ -Gc globuline des groupes sériques par immunoelectrophorèse sur gélose. *Jpn J Legal Med* (1978) **32**, 215-223.
17. Ishizu H, Shogano N, Yamamoto Y and Okamura K: Distribution of haptoglobin types in Kochi Prefecture. *Jpn J Legal Med* (1982) **36**, 641-644.
18. Toyomasu T and Tate K: The distribution of haptoglobin subtypes in a Japanese population. *Jpn J Legal Med* (1980) **34**, 125-127.
19. Shibata K: Haptoglobin, group-specific component, transferrin and  $\alpha_1$ -antitrypsin subtypes and new variants in Japanese. *Jpn J Hum Genet* (1983) **28**, 17-27.
20. Nakada N and Abe K: Genetic polymorphism of haptoglobin subtypes in a Japanese population. *Hum Hered* (1987) **37**, 376-380.
21. Teige B, Olaisen B and Teisberg P: Haptoglobin subtypes in Norway and a review of HP subtypes in various populations. *Hum Hered* (1992) **42**, 93-106.
22. Kojima T, Uchihi R, Yamamoto T, Tamaki K and Katsumata Y: DNA typing of the three HLA-class II loci from saliva stains. *Jpn J Legal Med* (1993) **47**, 380-386 (in Japanese).
23. Comey CT and Budowle B: Validation studies on the analysis of the HLA DQ $\alpha$  locus using the polymerase chain reaction. *J Forensic Sci* (1991) **36**, 1633-1648.
24. Watanabe Y, Takayama T, Hirata K, Yamada S, Nagai A, Bunai Y and Ohya I: Detection of ABO blood group and DNA types (MCT118, HLADQ $\alpha$ ) from mixed bloodstains. *Res Pract Forensic Med* (1995) **38**, 37-41 (in Japanese).
25. Kloosterman AD, Budowle B and Daselaar P: PCR-amplification and detection of the human DIS80 VNTR locus. Amplification conditions, population genetics and application in forensic analysis. *Int J Leg Med* (1993) **105**, 257-264.
26. Wiegand P, Budowle B, Rand S and Brinkmann B: Forensic validation of the STR systems SE33 and TC11. *Int J Leg Med* (1993) **105**, 315-320.
27. Miyauchi C: Identification of haptoglobin and transferrin types in blood stains. Reports of the National Research Institute of Police Science, Research on Forensic Science (1964) **17**, 238-242 (in Japanese).
28. Oya M and Takabe F: An improved method for detection of haptoglobin types from blood stains. *Z Rechtsmed* (1976) **77**, 105-107 (in German).
29. Sagisaka K and Shimada H: A device for haptoglobin typing of blood stains. *Act Crim Japon* (1997) **43**, 15-18.
30. Yoshioka N and Shimada H: Identification of haptoglobin phenotype from blood stains: Removal of hemoglobin from blood stain extract. Reports of the National Research Institute of Police Science, Research on Forensic Science (1979) **32**, 8-10 (in Japanese).
31. Strolorow MD and Wraxall BGD: An efficient method to eliminate streaking in the electrophoretic analysis of haptoglobin in bloodstains. *J Forensic Sci* (1977) **24**, 856-863.
32. Kasai K, Sakai I, Yoshida K and Mukoyama H: DNA typing of MCT118 locus from human bloodstains and body fluid stains by PCR amplification. Reports of the National Research Institute of Police Science, Research on Forensic Science (1992) **45**, 24-3 (in Japanese).
33. Kasai K, Fujii K, Senju H, Yoshida K, Sekiguchi K, Sato H and Seta S: Significance of sensitivity of STR (TH01) detection kit on forensic DNA typing from evidential samples. Reports of the National Research Institute of Police Science, Research on Forensic Science (1996) **49**, 21-24 (in Japanese).
34. Sparkes R, Kimpton C, Watson S, Oldroyd N, Clayton T, Barnett L, Arnold J, Thompson C, Hale R, Chapman J, Urquhart A and Gill P: The validation of a 7-locus multiplex STR test for use in forensic casework. (I) Mixtures, ageing, degradation and species studies. *Int J Legal Med* (1996) **109**, 186-194.
35. Takata S, Yamamoto Y and Ishizu H: IgA2 genotyping by polymerase chain reaction (PCR) using allele-specific amplification primers. *Acta Med Okayama* (1996) **50**, 1-9.
36. Azumi J, Funayama M and Morita M: DNA analysis of heated blood by PCR; in DNA Polymorphism, Yamanouchi H and Dewa K eds, Vol. 2, Toyoshoten, Tokyo (1994) pp216-222 (in Japanese).

---

Received December 18, 1997; accepted February 27, 1998.