

A Study of Facility Layout Method in Recycling Plant using AGV

Yutaka FUJIHARA*, Yoshiomi MUNESAWA** and Hirokazu OSAKI**

(Received March 1, 1999)

SYNOPSIS

Our country faces a serious problem of the environmental pollution by the mass production and the large quantity consumption of the industry product. The thoroughness of resources recycling has become necessary to solve these problems. As for the product design and the production control, how productivity should be improved has been discussed with extreme emphasis. But from now, as for the product design, both assemblability and disassemblability must be taken into consideration at the same time. And also in production management, it must be investigated how the used products can be recycled in the low cost. Therefore, the facility layout method with two phases in recycling plant, which is composed of both the procedure for the layout of facility group and the procedure for the layout of internal facility group by the optimal solution method and the suboptimal solution method by neural network, is proposed in this paper.

1. INTRODUCTION

Our country faces a serious problem of the environmental pollution by the waste by the mass production and mass consumption of the industry product. The thoroughness of the resources recycling has become necessary to solve these problems^{(1),(2)}.

As for the product design and the production control, it has been thought with extreme emphasis how productivity is improved. From now, not only assemblability but also disassemblability must be taken into consideration at the same time, and it must be investigated how the used product can be recycled in the low cost.

In this study, we propose the method of the facility layout with two phase using AGV at the automatic recycling factory where various used products are disassembled economically.

2. DISASSEMBLY PROCESS

In Japan, the law about the promotion of the use of the regenerated resources was enacted in the background of the effective use of the resources, the earth environmental problem, the aggravation of the disposal of waste, and so on.

* Matsue National College of Technology, Department of Control Engineering

** Department of Systems Engineering

And the 20 articles of refrigerator, television, car, and so on are specified as the 1st kind designated product, and the utilization of the whole of product or the part of product as the re-resources is suggested. At the same time, the product assessment in product design is required by manufacturers.

But, a quantitative evaluation technique and a standard in the recycling design are not established at present, and it has become the subject which must be resolved immediately.

In order to recycle the re-resources economically and efficiently, it is needed to improve the disassemblability of the collected wastes, the rate of automatic resolution and the efficiency of the disassembly work. The product must be designed in product design process in order to improve the disassemblability of the product. Next the automatic disassembly must be promoted in order to expect the high rate of automatic resolution and the efficiency of the disassembly work. In that case, the automation of assembly and disassembly must be considered simultaneously.

The disassemblability of products is one of the evaluation of product recycling and it is combined deeply with the fastening method used in assembly process. The fastening method is classified as follows⁽³⁾⁻⁽⁶⁾.

- (1)mechanical fastening
- (2)physical fastening
- (3)chemical fastening

Mechanical fastening is the fastening by plastic deformation or elastic deformation such as fastening with rivets, inserting pins or keys and fixing a bolt with a nut. Physical fastening is to combine materials by melting with heat or pressure such as welding, soldering and pressure welding. Chemical fastening is the fastening by utilizing chemical reaction such as adhesive bonding.

The assemblability and disassemblability of these three fastenings are evaluated by five ranking(A:very easy,B:easy,C:normal,D:difficult,E:very difficult) as indicated in Table 1. Facility layout in the automated recycle factory must be designed considering these disassemblability of each method of fastening.

Table 1. Fastening Method and Assemblability/ Disassemblability

Fastening	Assemblability	Diassemblability
thread fastening	A	A
calking	A	E
insertion	B	D
press fitting	D	B
welding	E	D
soldering	A	A
adhesive bonding	B	A

3. PROPOSED LAYOUT METHOD

In this study, transportation is done automatically by an Automated Guided Vehicle (AGV). N_s stations are allocated in the loop routing layout and an AGV uni-directionally transports between stations in which facilities are installed. As shown in Fig.1, products for recycling are stored in the automatic warehouse, disassembly is done in each station and finally main recycling parts are stored in the automated warehouse.

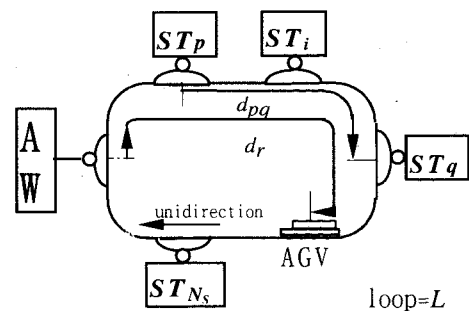

Fig.1 Loop Routing Layout

And the parts except the main recycling parts from the disassembly process are collected by the conveyer which is installed in the circumference of the station, and are finally disposed.

The fastening method used for product consists of mechanical fastening(such as thread fastening,calking,insertion and press fitting), physical fastening(such as welding and soldering) and chemical fastening(such as adhesive bonding etc.) as above mentioned in Chapter 2. The facilities for disassemble of products assembled by physical fastening and chemical fastening have a bad influences such as high temperature, noise and dust on the surrounding facility. Because of this reason, we propose the layout method with two stages. In the first stage, facilities used for disassemble are divided into group by fastening method and facility group of same fastening is allocated . And in the second stage , the layout of facility is determined in each group.

3.1 Layout of Facility Group

Facilities used for disassemble are grouped according to the function of fastening method of each facility . Facility group is allocated to station of loop routing layout considering the bad influence by high temperature ,noise and dust of facility for physical and chemical fastening by the following procedure.

(step 1)

Divide facility M_{i_p} into the facility group G_p , where $p = 1,2,3$ and $G1$ is the facility group of disassemble for mechanical fastening , $G2$ is the facility group for physical fastening and $G3$ is the facility group for chemical fastening.

$$M_{i_p} \in G_p, \quad i_p = 1,2,\dots,N_p, p = 1,\dots,3$$

,where N_p is the number of facility in group G_p .

(step 2)

Calculate the quantity $FF(p)$ of carrying out from the facility group G_p as follows.

$$FF(p) = \sum_{i_p=1}^{N_p} \sum_{j_q=1}^{N_q} f_{i_p,j_q} \tag{1}$$

,where

$$M_{j_q} \in G_q, \quad j_q = 1,2,\dots,N_q, q \neq p$$

(step3)

Allocate the facility Group G_{p_0} which has the maximum value of $FF(p)$ to the nearest station group from the warehouse according to the direction of AGV routing. Next allocate the facility group of the second large value of $FF(p)$ and finally Allocate the facility group of the smallest value of $FF(p)$ to the farthest station group from the warehouse.

3.2 Layout of Facility in Each Group

Because of the uni-directional move of an AGV, if the sequence of the disassembly stations allocated along the loop routine layout is consistent with the sequence of the disassembly processes of the product for recycling, an AGV moves only one cycle for that product. But if the sequence of the disassembly stations is different from the sequence of the disassembly processes , an AGV must move more than one cycle to transport that product. Thence, the facility for disassembly must be arranged for an AGV to transport products by the minimum transportation cycles. Beginning from the neighbor station of the automated warehouse, each station is numbered from 1 to N_s according to the loop.

Facility layout problem in each facility group can be so described as to find the optimal assignment of N_p facilities to N_p stations in order to minimize the volume of transportation which is the remaining volume for dismantling of next process. In the facility layout problem in which N_p facilities are assigned to N_p available stations, $s(i)$ denotes the station number to which the facility i is assigned , and also $S = \{s(1),s(2),\dots,s(N_p)\}$ denotes the assignment vector of the facility layout. The

objective function of facility layout problem can be expressed as Equation (2), where the transportation volume from the facility i to the facility j is represented as f_{ij} .

The objective function :

$$F(s) = \sum_{i=1}^{N_p} \sum_{j=1}^{N_p} f_{ij} \eta(s(i), s(j)) \quad (2)$$

where

$$\eta(s(i), s(j)) = \begin{cases} 1, & \text{if } s(i) > s(j), \\ 0, & \text{otherwise.} \end{cases} \quad (3)$$

When the station number that the facility i is arranged is greater than that of the facility j , Equation (3) means that the direction of the transportation by an AGV becomes the reverse direction, but an AGV transports uni-directionally and an AGV makes two revolution around an oval path.

3.2.1 Method for Optimal Layout in Facility Group

The layout method in facility group which can obtain the optimal solution is as follows.

(step 1)

Arrange the facility in which all products for recycling are stored in the automated warehouse after disassembly in the last station. This procedure can be expressed by Equation (4).

$$\begin{aligned} \text{if } f_{ij}=0 \text{ and } f_{hi} \geq 0 \text{ for all } h \text{ and } j \\ \text{then } s_0(i)=N_p. \end{aligned} \quad (4)$$

This arrangement becomes a part of the optimal layout and Equation(4) can be proved as follows.

Firstly, the objective function is rewritten as Equation(5).

$$\begin{aligned} F(s) &= \sum_{h=1}^{N_p} \sum_{l=1}^{N_p} f_{hl} \eta(s(h), s(l)) \\ &= \sum_{h=1}^{N_p} \sum_{\substack{l=1 \\ l \neq i}}^{N_p} f_{hl} \eta(s(h), s(l)) + \sum_{h=1}^{N_p} f_{hi} \eta(s(h), s(i)) \end{aligned} \quad (5)$$

Because of $f_{hi} \geq 0$ for all h , facilities must be allocated so that the equation $\eta(s(h), s(i)) = 0$ is satisfied any time in order to minimize the objective function. Therefore, the equation $s_0(i) = N_p$ must be always satisfied so that we obtain Equation(6).

$$s(h) < s(i) \quad (6)$$

(step 2)

Arrange the facility in which all products for recycling are delivered from the automated warehouse before disassembly in the first station. This procedure can be expressed by Equation (7).

$$\begin{aligned} \text{if } f_{hi}=0 \text{ and } f_{ij} > 0 \text{ for all } h \text{ and } j \\ \text{then } s_0(i)=1. \end{aligned} \quad (7)$$

This arrangement becomes composed of a part of the optimal layout and Equation(7) can be proved as follows. Firstly, the objective function is rewritten as Equation(8).

$$\begin{aligned}
 F(S) &= \sum_{h=1}^{N_p} \sum_{j=1}^{N_p} f_{hj} \eta(s(h), s(j)) \\
 &= \sum_{\substack{h=1 \\ h \neq i}}^{N_p} \sum_{j=1}^{N_p} f_{hj} \eta(s(h), s(j)) + \sum_{j=1}^{N_p} f_{ij} \eta(s(i), s(j))
 \end{aligned} \tag{8}$$

Because of $f_{ij} \geq 0$ for all j , facilities must be allocated so that the equation $\eta(s(i), s(j)) = 0$ is satisfied any time in order to minimize the objective function. Therefore, the equation $s(i) = l$ must be always satisfied so that we obtain Equation(9).

$$s(i) < s(j) \tag{9}$$

(step 3)

If a part of the optimal layout can be obtained by (step 1) or (step 2), remove the row and the column concerned with the allocated facility in the flow matrix. For example, if $s(i) = N_p$ in (step1), eliminate all elements of the i th row and the j th column in the flow matrix.

Return to (step 1) and repeat the procedure about the flow matrix until every facilities are allocated.

(step 4)

If every facility can be allocated, the layout vector S_0 becomes the optimal layout solution. If all of the facilities or some of the facilities remain unallocated, obtain the sub optimal layout by the method using the neural network described in the next section.

3.2.2 Layout Method Using Neural Network for Suboptimal Layout in Facility Group

Neural networks to mimic the human brain are classified by the two types; one is the hierarchical structure, the other is the inter-connected structure⁽⁷⁾. The former consists of the input layer, some of the middle layers and the output layer, and the connecting direction is from the input layer to the output layer. This neural network is called Perceptron neural network which is used mainly in the computer, such as pictorial pattern recognition or speech recognition. The latter is called Hopfield neural network and the direction of connection of neurons differ from the former, and the neural network in Hopfield type⁽⁸⁾ is constructed by the symmetrical neuron connections. Furthermore, neurons change asynchronously their state and finally reach the stable equilibrium. Considering the analogies between neural network and physical systems, the energy function was introduced to express the state of neural network, and the neurons of Hopfield network change their state in such a manner as they minimize the energy function. For solving the facility layout problem by using Hopfield neural network⁽⁹⁾⁻⁽¹¹⁾, we use the $N_p \times N_p$ square neuron matrix, where rows are correspondent to facilities and also columns are correspondent to stations for facilities to be allocated. We represent the output of the neuron (X, i) as V_{Xi} which range of value is from 0 to 1. When $V_{Xi} = 1$, the neuron is in exiting state and it means that the facility X is allocated to the station i . Conversely when $V_{Xi} = 0$, the neuron is in the most stable state, which means that the facility does not allocate the station corresponding to that neuron.

The general energy function of the neural network can be expressed by Equation (10), where $T_{Xi Yj}$ is the coefficient of the connection between the neuron (X, i) and the neuron (Y, j) , and θ_{Xi} is the threshold value of the neuron (X, i) .

$$E = -\frac{1}{2} \sum_{X=1}^{N_p} \sum_{i=1}^{N_p} \sum_{Y=1}^{N_p} \sum_{j=1}^{N_p} T_{XiYj} V_{Xi} V_{Yj} - \sum_{X=1}^{N_p} \sum_{i=1}^{N_p} \theta_{Xi} V_{Xi} \quad (10)$$

According to the change of neuron state, the value of energy function is reduced and finally reaches the lowest value, where the state of neural network reaches a state of equilibrium. By using this characteristic of neural network, the optimization problem such as facility layout problem can be solved, but the optimal solution cannot always be obtained because of the convergence to the local minima.

Herein, we introduce the objective function expressed in Equation (11) for the facility layout problem formulized by Equation (2) and (3)

$$\begin{aligned} \phi = & \frac{A}{2} \sum_{X=1}^{N_p} \sum_{Y=1}^{N_p} \sum_{\substack{j=1 \\ j \neq i}}^{N_p} V_{Xi} V_{Yj} + \frac{B}{2} \sum_{i=1}^{N_p} \sum_{X=1}^{N_p} \sum_{\substack{Y=1 \\ Y \neq X}}^{N_p} V_{Xi} V_{Yi} \\ & + \frac{C}{2} \left(\sum_{X=1}^{N_p} \sum_{i=1}^{N_p} V_{Xi} - N_p \right) + \frac{D}{2} \sum_{X=1}^{N_p} \sum_{Y=1}^{N_p} \sum_{i=1}^{N_p} \sum_{\substack{j=1 \\ j < i}}^{N_p} f_{XY} V_{Xi} V_{Yj} \end{aligned} \quad (11)$$

where A,B and C are positive weight factors. The first term means that from the constraints of facility layout, each facility must be allocated to only one station and the second term means that each station must accept only one facility for allocation. The third term corresponds to the whole number of station and facility, and the fourth term corresponds to the energy function of neural network.

By equating the corresponding coefficients of the energy function of Equation (10) and the objective function of Equation(11), the next equations can be obtained.

$$\begin{aligned} T_{XiYj} = & -A \cdot \delta_{XY}(1 - \delta_{ij}) - B \cdot \delta_{ij} \cdot (1 - \delta_{XY}) \\ & - C \quad - D \cdot f_{XY} \end{aligned} \quad (12)$$

$$\theta_{Xi} = C \cdot N_p \quad (13)$$

where δ_{ij} is a Kroneker delta function defined by

$$\delta_{ij} = \begin{cases} 1, & i = j \\ 0, & \text{otherwise} \end{cases} \quad (14)$$

Furthermore, $V_{Xi}(t)$ denotes the variable of neuron state at time t and $V_{Xi}(t+1)$ denotes that of the change of times $t+1$, and we can also obtain Equation(15).

$$\begin{aligned} V_{Xi}(t+1) &= V_{Xi}(t) + \Delta \cdot \frac{dV_{Xi}}{dt} \\ &= V_{Xi}(t) + \Delta \cdot \left\{ -V_{Xi}(t)(1 - V_{Xi}(t)) \right\} \frac{\partial E}{\partial V_{Xi}(t)} \\ &= V_{Xi}(t) + \Delta \cdot V_{Xi}(t)(1 - V_{Xi}(t)) \cdot \left\{ \sum_{X=1}^{N_p} \sum_{i=1}^{N_p} T_{XiYj} V_{Xi} + \theta_{Xi} \right\} \end{aligned} \quad (15)$$

where Δ is the constant value.

4. COMPUTATIONAL RESULTS

To confirm the effect of the procedures of layout above mentioned, we give two kinds of sample layout problems. The first sample problem in which the number of facilities and stations is both 6 and it can be solved by the method described in Section 3.2.1, so we can get the optimal layout solution. On the other hand, the second sample problem of 8 stations and 8 facilities cannot obtain the optimal solution for its own characteristic of the flow matrix, so that we utilize the layout method using the neural network mentioned in Section 3.2.2 to obtain the suboptimal solution.

4.1 Example Problem for Optimal Solution

Table 2. Flow Matrix

		T O					
		M_1	M_2	M_3	M_4	M_5	M_6
F	M_1	0	110	0	0	200	50
	M_2	0	0	0	0	0	0
R	M_3	60	100	0	0	90	40
O	M_4	80	60	30	0	100	180
M	M_5	0	70	0	0	0	55
	M_6	0	22	0	0	0	0

Table 3. Flow Matrix of Facility Group

		T O					
		M_1	M_3	M_4	M_2	M_5	M_6
F	M_1	0	0	0	110	200	50
	M_3	60	0	0	100	90	40
R	M_4	80	30	0	60	100	180
O	M_2	0	0	0	0	0	0
M	M_5	0	0	0	70	0	55
	M_6	0	0	0	22	0	0

From the operation process chart of the product for recycling ,the flow matrix of 6 facilities and 6 stations is given as Table 2. Considering the direction of physical logistics in factory, the flow matrix is asymmetrical.

In this case, facility M_1 is used for disassemble of insertion fastening and M_2, M_3, M_4, M_5, M_6 disassemble product of welding, thread fastening, calking, press fitting and soldering respectively.

Firstly , M_1, M_3, M_4 can be classified in one group G_1 because these facilities are used for mechanical fastening and also M_2, M_5, M_6 are used for physical fastening so that we can gather into group G_2 . By this grouping facilities, the flow matrix of Table 2 can be modified as Table 3. By the equation(1), $FF(1)=930$ and $FF(2)=0$. From this result, the facility group G_1 is firstly allocated and G_2 is secondly allocated.

Next, by the procedure written in 3.2.1 ,the layout in each facility group can be determined. From the result of group G_1 , facilities M_4, M_3 and M_1 are allocated to stations ST_1, ST_2 and ST_3 respectively, and also in group G_2 , $M_5, M_6,$ and M_2 are allocated to ST_4, ST_5 and ST_6 respectively. Then we can obtain the optimal layout solution as follows.

$$S_0 = \{ 3, 6, 2, 1, 4, 5 \} \tag{16}$$

4.2 Example Problem for Suboptimal Solution by Neural Network

In the case of the flow matrix of Table 4, we can obtain two facility group, $G_1=\{M_1, M_2, M_3, M_5\}$ for mechanical fastening and $G_2=\{M_4, M_6, M_7, M_8\}$ for physical fastening according to the fastening method. By this grouping facilities, the flow matrix of Table 4 can be modified as Table 5 .

For determining the layout of these facility groups, we obtain $FF(1)=768$ and $FF(2)=855$ from the equation(1). So the facility group G_1 is allocated to the station group $\{ST_1, ST_2, ST_3, ST_4\}$ which is the nearest from the warehouse and G_2 is allocated to the another station group $\{ST_5, ST_6, ST_7, ST_8\}$ which is the farthest from the warehouse.

In the next stage, we determine the internal layout of the facility group G_1 and G_2 respectively. In this case, equation (4) and (7) cannot be satisfied , so that the optimal layout solution can be obtained only by the exact solution approach.

Table 4. Flow Matrix

		T O							
		M_1	M_2	M_3	M_4	M_5	M_6	M_7	M_8
F R O M	M_1	0	17	30	53	94	17	70	22
	M_2	49	0	8	38	27	36	98	53
	M_3	76	64	0	78	82	15	62	31
	M_4	34	91	51	0	60	78	93	86
	M_5	86	67	75	58	0	35	20	82
	M_6	41	46	97	12	21	0	73	40
	M_7	78	75	95	2	31	75	0	58
	M_8	4	95	31	5	44	91	57	0

Table 5. Flow Matrix of Facility Group

		T O							
		M_1	M_2	M_3	M_5	M_4	M_6	M_7	M_8
F R O M	M_1	0	17	30	94	53	17	70	22
	M_2	49	0	8	27	38	36	98	53
	M_3	76	64	0	82	78	15	62	31
	M_5	86	67	75	0	58	35	20	82
	M_4	34	91	51	60	0	78	93	86
	M_6	41	46	97	21	12	0	73	40
	M_7	78	75	95	31	2	75	0	58
	M_8	4	95	31	5	5	91	57	0

Therefore, we introduce the method for suboptimal solution using neural network above mentioned.

All the elements of the neuron matrix consisting of output values of neural network are set 0.5 at the initial state. And from previous numerical experiments, the weight factors of Equation (12) are chosen as $A=5.0, B=5.0, C=5.0, D=5.0$ which is obtained from the previous simulation experiment.

Firstly we determine the layout of the facility group G_1 .

The energy function of the neural network are shown in Fig.2. Initially the neural network are very nearly uniform, in other words, they are in the stable state and as time passes some of the cells increase their value and others decrease their value, and finally they converge to the final independent state 500 iterations. The value of the energy function is 1925.05 in the initial state and that value decrease according to the times of iteration shown in Fig.2 and finally reach the minimum value , 18.02 after 500 iterations.

The final outputs of the neural network produce the permutation array with one neuron "on" and the rest "off" in each row and column and we can determine a unique facility layout from this result.

And we can obtain the layout vector S_1 of the facility group G_1 represented by Equation(17) and the value of the objective function of layout becomes 747.0 and the elapsed time for calculation by C program of personal computer(CPU: Intel Pentium 200MHz) is 3.344 seconds.

$$S_1 = \{3, 4, 2, 0, 1, 0, 0, 0\} \tag{17}$$

Furthermore, the layout of the facility group G_2 can be determined by neural network and the layout vector S_2 is shown in Equation(18) and the value of the objective function of layout becomes 865.0

$$S_2 = \{0, 0, 0, 7, 0, 6, 5, 8\} \tag{18}$$

From these layout vector S_1 and S_2 , the final layout vector represented in Equation(19) can be obtained by neural network and the value of the objective function of this layout vector is 1612.0.

$$S = \{3, 4, 2, 7, 1, 6, 5, 8\} \tag{19}$$

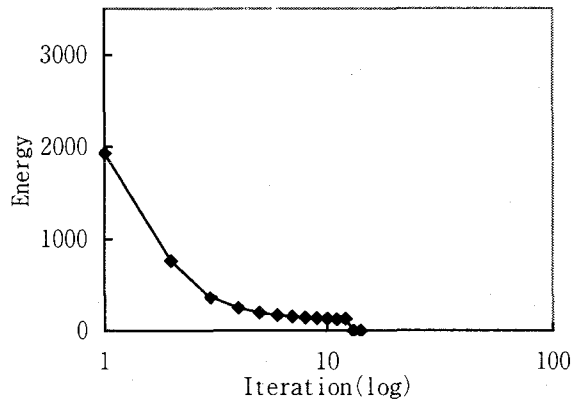

Fig 2. Energy function

5. CONCLUSIONS

In this paper, we proposed the layout method with two stage to allocate facilities to stations in recycling factory in which transportation is done by an uni-directional loop routing AGV. In the first stage, the layout of the facility group which is consisted of the same fastening method. And in the second stage , the layout of facility of the facility group . In the second stage ,we adopt neural network to obtain the suboptimal layout in the case the optimal solution can not be obtained because of dissatisfaction of the approval condition of the optimal solution. And we confirmed the effectiveness of the proposed procedure by sample problems.

REFERENCES

- (1)Kroll,E,Beardsley,B.and Parulian,A. *A Methodology to Evaluate Ease of Disassembly for Product Recycling*, IIE Transactions,Vol.28,(1996),pp.837-845.
- (2)Tanokura,Y., *Design Corresponding to Recycling*, Nikkei Mechanical, 1995.1.9,pp.20-37.
- (3)Nakamura,S., *Counter Measure Making for Recycle Problems by Using IE/QC,etc*, Management System of JIMA,Vol.7,No.1,(1996),pp.52-59.
- (4)Nakamura,S., *Easy Re-Assembibility & High Assembibility Reviewed Methods and Usages to New Products*, Management System of JIMA,Vol.7,No.2,(1997),pp.120-128.
- (5)Nakamura,S., *Reviewed Method for Easy Recovery to Used Products for Recycle*, Management System of JIMA,Vol.7,No.3,(1997),pp.184-189.
- (6)Nakamura,S., *Easy Recycle Process and Usage Review Methods on a Plant*, Management System of JIMA, Vol.7,No.4,(1997),pp.223-229.
- (7)Asou,E.,*Neural Network Information Processing*(in japanese),(1988),sangyou-tosho.
- (8)Hopfield,J.J. and Tank,D.W.,*"Neural" Computation of Decisions in Optimization Problems*,Biological Cybernetics, Vol.52,(1985),pp.141-152.
- (9)Fujihara,Y. and Osaki,H., *Plant Layout Method by Neural Network*, Transactions of The Japan Society of Mechanical Engineers, Vol.59,No.558,C,(1993),pp.600-605.
- (10)Takeda,M. and Goodman,J.W., *Neural Networks for Computation: Number Representations and Programming Complexity*, Applied Optics ,Vol.25,No.18,(1986),pp.3033-3046.
- (11)Kirkpatrick,S.,Gelatt,Jr. and Vecchi,M.P., *Optimization by Simulated Annealing*, Science,Vol.220,No.4598,(1983), pp.671-680.