

Radiative Characteristics of Frost Layer in Frosting and Defrosting Processes

Hideo INABA* , Hideo OTAKE** and Shigeru NOZU*

(Received January 16 , 1992)

SYNOPSIS

Radiative characteristics of the frost layer melted by radiative heat are experimentally examined. A frost layer is heated from above by the radiative heat from a halogen lamp set. Thermal radiation of the lamp has the wavelength spectrum characteristics similar to those of the solar radiation. The effect of the environmental temperature upon the frost melting process is clarified in experiments. The optical characteristics of reflectivity, absorptivity and transmissivity of the frost layer during the melting of the frost layer are measured using special measuring instruments.

1. Introduction

The frosting is a phenomenon which can be observed on a cooling surface with a temperature below the freezing point of water by solidification of water and sublimating solidification of water vapor. The frost layer brings a decrease of the heat transfer rate in the evaporator of a refrigerator and a heat pump. The defrosting is therefore indispensable to maintain the efficiency of the heat exchanger. Many reports^{1) ~ 6)} have been seen concerning the physical properties, for example, the density and the thermal conductivity of

* Department of Mechanical Engineering

** Graduate School of Natural Science and Technology

the frost layer, and the heat and mass transfer between the frost layer and the moist air. However, few papers ^{7),8)} deals with the melting process of the frost layer, and optical characteristics of melting frost layer by the radiative heat. The defrosting system is generally done using the hot gas by a reverse cycle of refrigerator, electric heater, water solution sprinkling and the hot air blowing. The present study based on the previous study ^{9) ~ 11)} of the snow melting by the insolation investigates experimentally the melting phenomena of the frost layer. In particular, this report presents the melting process of the frost layer, thermal properties of reflectivity and transmissivity of the frost layer during the defrosting.

2. Experimental apparatus and procedures

A schematic diagram of the experimental apparatus is shown in Fig. 1. A test part is located at the lower part in a 2.5m (width) x 3.0m (depth) x 1.8m (height) test room, and its temperature is controlled by the cooling heat exchanger. The test part is

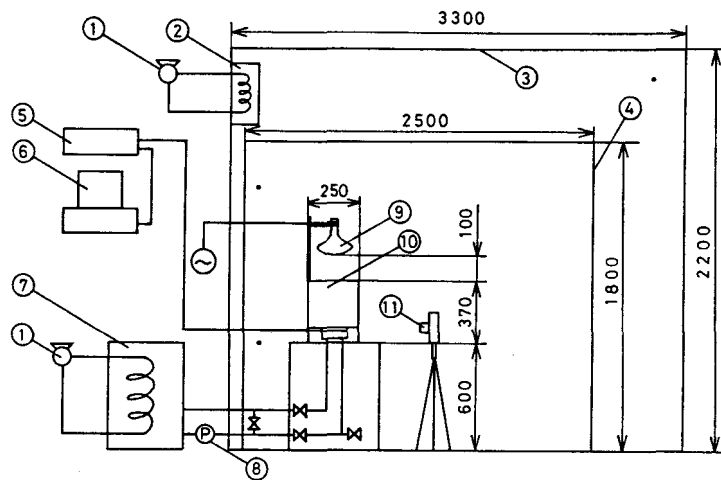

- | | |
|------------------------|--------------------------|
| ① Refrigerator | ② Cooling Heat Exchanger |
| ③ Low Temperature Room | ④ Vinyl-Sheet Box |
| ⑤ Data Record System | ⑥ Computer |
| ⑦ Brine Tank | ⑧ Pump |
| ⑨ Halogen Lamp | ⑩ Test Section |
| ⑪ Camera | • Thermocouple |

Fig. 1 Schematic diagram of experimental apparatus

installed in the partition room made of vinyl sheet to reduce the influence of a cold air flow in a low temperature room. Both the frosting and defrosting experiments are performed in the partition room. In the frosting experiments, the brine controlled at the temperature of -25°C flows below the cooling copper plate, and the frost layer is formed on the cooling copper plate. On the other hand, in the case of the defrosting experiments the formed frost layer is radiatively heated from above by the halogen lamp as the heat source.

Figure 2 shows a detail of the test part. The cooling plate is made of a 54mm (width) x 111mm (length) x 5mm (height) copper plate, and it is possible to be dismantled the test part to measure the amount of a frost layer. The lower side of the cooling plate is composed of a heat flow meter, electronic cooling devices and the cooling chamber. The heat flow meter of a teflon sheet in thickness of 2mm below the cooling plate is installed to measure the heat flux. The electronic cooling devices below the heat flow meter is used to control the temperature of the cooling surface. During the frosting experiment, the cooling plate is cooled down by

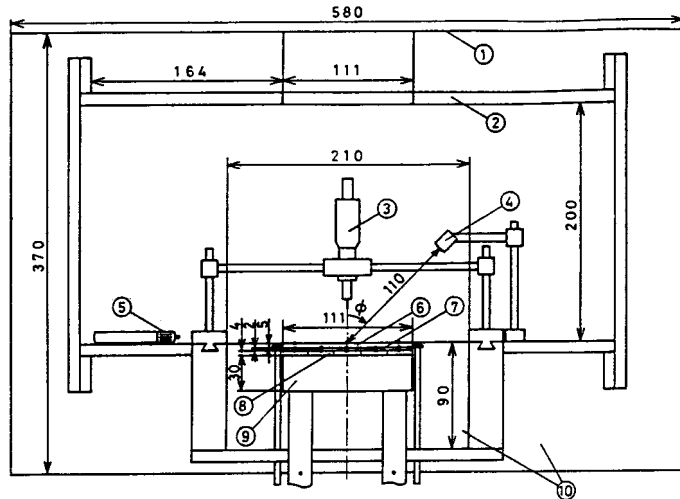

- | | |
|-------------------|------------------------------|
| ① Aluminium Foil | ② Acrylic Plate |
| ③ Micrometer Head | ④ Radiation Flux Sensor |
| ⑤ Humidity Sensor | ⑥ Copper |
| ⑦ Teflon | ⑧ Heating and Cooling Device |
| ⑨ Cooling Chamber | ⑩ Insulator |
| • Thermocouple | |

Fig. 2 Detail of test part

the temperature control system, and the desired thickness of the frost layer is obtained on the cooling surface. The side wall of the cooling part is covered with the thermal insulation material to reduce the heat loss. The ambient temperature and humidity of the still air inside the test part are controlled, and they are measured using the thermocouples and hygrometer, respectively. The micro-meter system is set above the frost surface to measure the height of the frost layer, and the radiant heat flux sensor is installed above it to measure the heat flow by reflection on the frost surface during the experiments. The top surface besides the test part is covered with aluminium foil of 50 μm in thickness to minimize the absorption of the radiant energy. The hygrometer is installed in the test part and its output is recorded by a pen-recorder. The temperatures are measured by C-C thermocouples of 0.1mm in diameter, and its outputs are recorded by a data-recorder. Three thermocouples on the cooling plate are located at intervals of 44mm, and five thermocouples at the bottom of the cooling plate are located at intervals of 22mm. A 35mm camera is located in front of the test part to observe the frost behavior in the frosting and defrosting process. The centrifugal water separator is used to measure the melting water content in the frost layer during the defrosting experiments.

Figure 3 indicates a detail of the centrifugal water separator. The cooling and heating devices are installed to keep the sample temperature at 0°C. The cylindrical drum rotates by the motor, and the holes of 5mm i.d. at interval of 20mm are bored on the drum side wall to sprinkle the melting water in the frost bulk outside. The

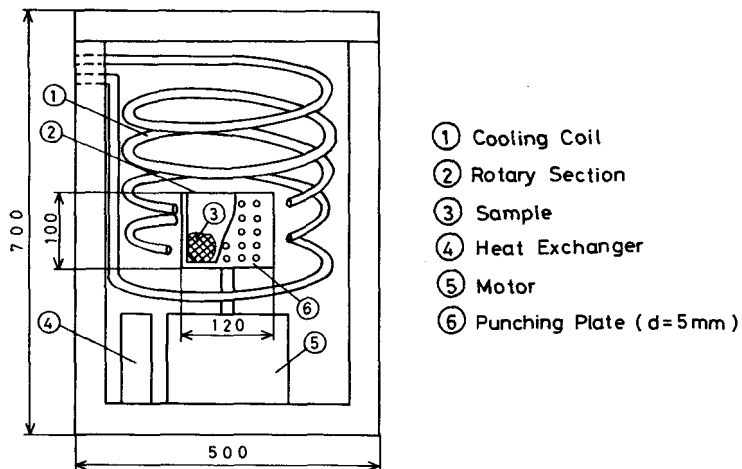

Fig. 3 Detail of centrifugal water separator

operating time of the centrifugal water separator is determined at about 30 seconds, and the relative measuring error would be within 5.6% by the preparatory experiment results.

The frosting experiments are performed after controlling the temperature of the cooling plate by the cooling devices. Before every run the cooling plate is wrapped by the aluminum foil of 50 μm in thickness, and then the aluminum foil is taken out when the pre-determined conditions are attained. The air condition in the test section is controlled to maintain the temperature and humidity at prescribed values through the whole testing period. The amount of the frost layer is measured by an automatic platform type weight scale, and the height of the frost layer is measured by micro-meter system. The defrosting experiments by the halogen lamp are performed using the frosting layer formed on the cooling surface for about 24 hours at constant temperature and humidity condition. The cross section and the surface of the frost layer are taken at the photographs during the test run. During the defrosting experiments, a part of the melting frost layer is scratched off with a knife edge, and its weight is measured by the automatic platform type weight scale. The obtained melting frost layer is put in the vessel of the centrifugal water separator, and the weight of ice in the frost layer is measured after separating water in the moist frost layer by the separator. The elapsed reflectional heat during test runs is measured by the radiant heat flux sensor, and its outputs are recorded continuously by the pen-recorder.

3. Experimental results and discussions

3.1 Growth process of the frost layer

The frost is complicately formed by the effects of the cooling surface temperature, the flowing velocity, the humidity and the temperature of the moist air. The growth processes is generally classified into following three processes.

- (1) The developing period of the frost column
- (2) The growing period of the frost layer
- (3) The maturity period of the frost layer

Figure 4 shows the photographs of the surface and the cross section of the frost layer in case of the frosting under the experimental conditions as shown in table 1 as a function of the time

Table 1 Frosting conditions

Temperature of Cooling Surface T_C [$^{\circ}\text{C}$]	-25
Environmental Temperature T_{∞} [$^{\circ}\text{C}$]	10 ~ 15
Relative Humidity ψ [%]	60 ~ 70

elapsed. At the beginning of frosting it is seen in figure 4 (a) that the film of the frost layer is formed on the cooling plate, and the sharp crystals are partially grown. The frost layer of this developing period of the frost column has a large porosity and roughness on the frost surface. As the time elapses, the dendritic crystals are formed and grown horizontally as shown in figure 4 (b). The density of the frost layer becomes larger, while the roughness of frost surface is smaller. After the long time elapse in figure 4 (c), the frost surface is melt because its surface temperature increases until the melting point due to the increase of the thermal resistance of the frost layer. Therefore, the film of melting water is formed upper on the frost layer, and then the ice layer is formed due to recrystallization of the melting water. Finally the frost layer reaches at the steady state, and the growth of the frost layer ceases. The frost samples in the defrosting experiment are selected at the frost condition of the growing period as shown in figure 4 (b).

3.2 The melting process of the frost layer

Figure 5 shows the photographs of the melting process of the frost layer by the halogen lamp as the heat source under the experimental conditions as shown in table 2. The photograph of the frost layer in the growing period of the frost layer before starting the melting experiment is shown in figure 5 (a). At eight minutes elapse from starting of the melting experiment in figure 5 (b), the frost surface is melt by the radiative heat from the halogen lamp, and the small water drops are produced between frost tips. It follows that the melting water penetrates into the porosity of the frost layer near the frost surface by the capillary force, and the roughness of the frost surface becomes large, as shown in figure 5 (c). It can be seen in figure 5 (d) after forty-five minutes elapse that a greater part of the porosity of the frost layer is saturated with the melting water, and the translucent frost layer is formed. Thereafter the

cross section of frost layer

frost surface

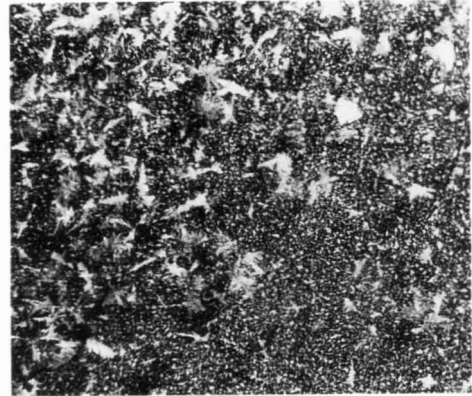
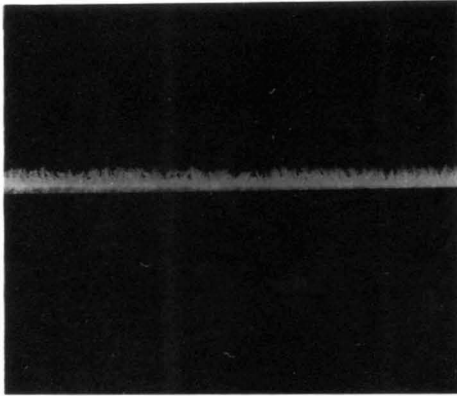

(a) $t=5$ [min]

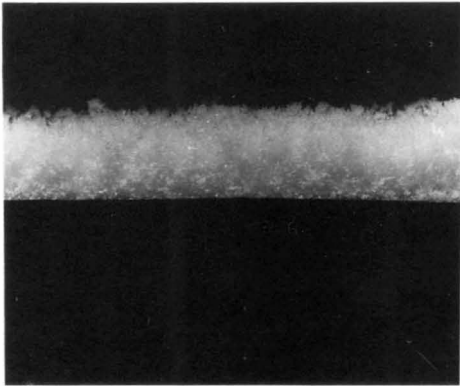

(b) $t=3$ [hour]

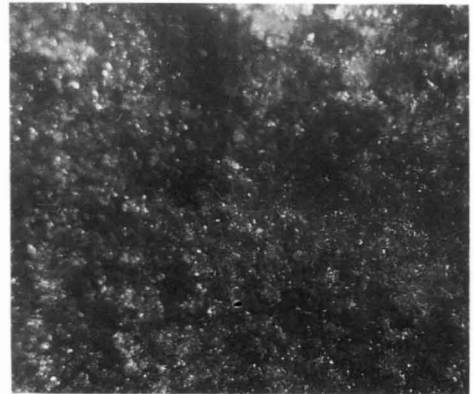
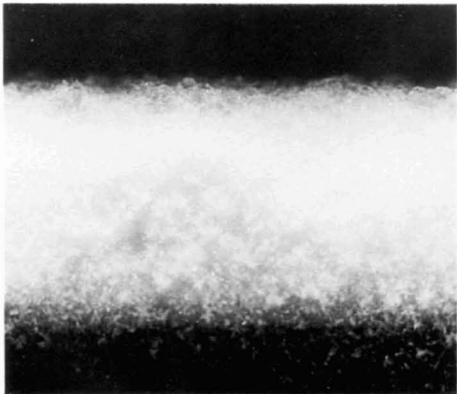

(c) $t=25$ [hour]

Fig. 4 Growing process of frost layer

Table 2 Frosting and defrosting conditions

	Frosting	Defrosting
Temperature of Cooling Surface T_C [$^{\circ}\text{C}$]	-25	0
Environmental Temperature T_{∞} [$^{\circ}\text{C}$]	10 ~ 15	0
Relative Humidity ψ [%]	40 ~ 50	40 ~ 50
Frosting Time t_0 [hour]	20	—
Radiative Heat Flux Q_H [kW/m^2]	—	0.28

cross section of frost layer

frost surface

(a) $t=0$ [min](b) $t=8$ [min]

Fig. 5 Melting process of frost layer

cross section of frost layer



frost surface

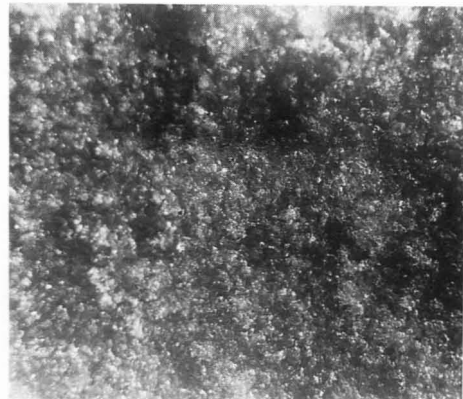
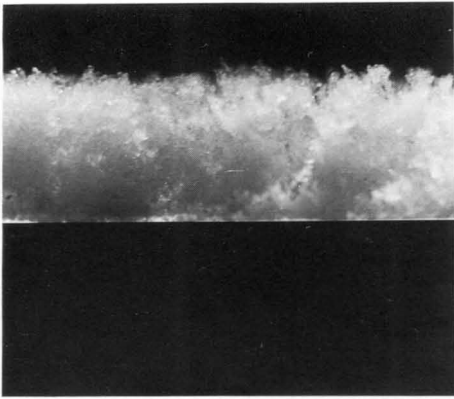
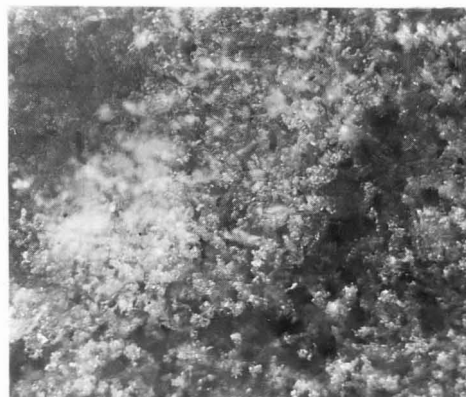
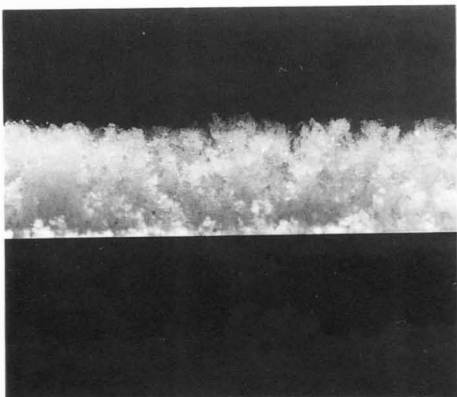
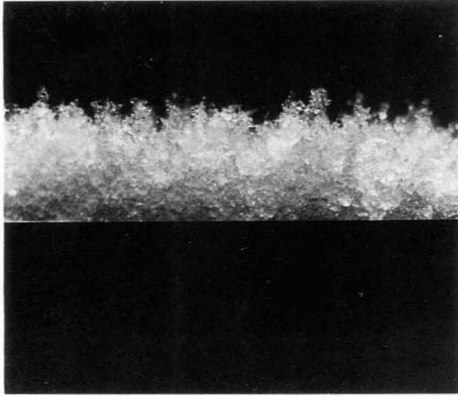
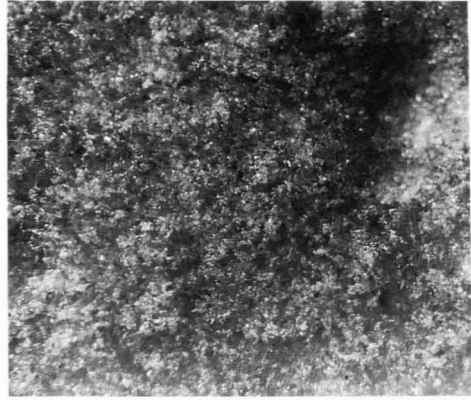

(c) $t=15$ [min]

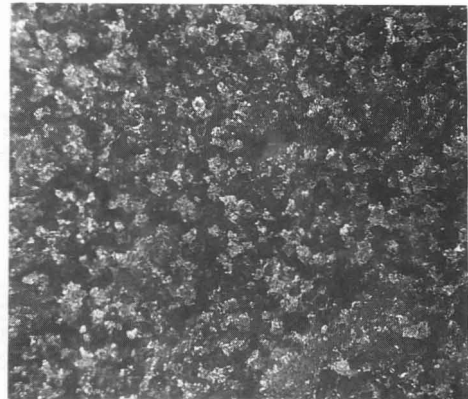
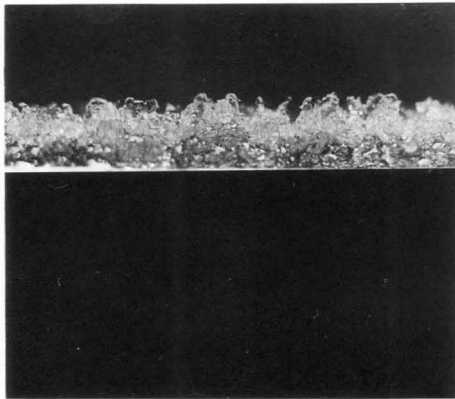

(d) $t=45$ [min]

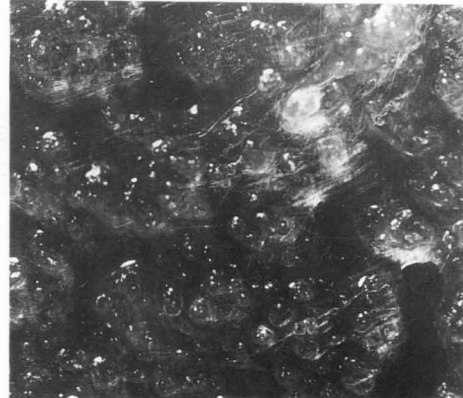
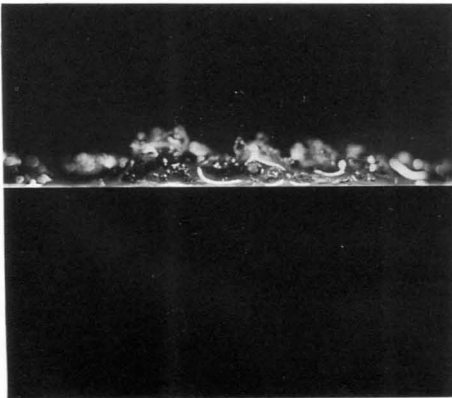

(e) $t=60$ [min]

Fig. 5 Melting process of frost layer

whole porosity of the frost layer is saturated with the melting water, the water saturation frost layer is formed as shown in Figure 5 (e). Finally the whole of the frost layer is melt and the melting water remains on the cooling plate. In the present study, the perfect melting of frost layer is defined by the disappearance of the whole frost.

The height of the frost layer obtained by the photograph of the melting process of the frost layer is plotted in Figure 6 as a function of the elapsed time. At eight minutes elapse from starting of experiment, the height of frost layer may be a little difference corresponding to the height before starting of the experiment. Subsequently, the height of the frost layer decreases gradually during the melting water penetration toward the cooling surface. However at forty-five minutes goes by, the whole porosity of the frost layer is filled with the melting water, and the height of the frost layer decreases sharply. This tendency can be explain by the fact that the emissivity of the frost layer increases with an increase of the melting water in the defrosting frost layer.

3.3 Measurement of water saturation rate in a frost layer

Figure 7 indicates the volumetric water saturation rate in the frost layer with time, which is measured by the centrifugal water

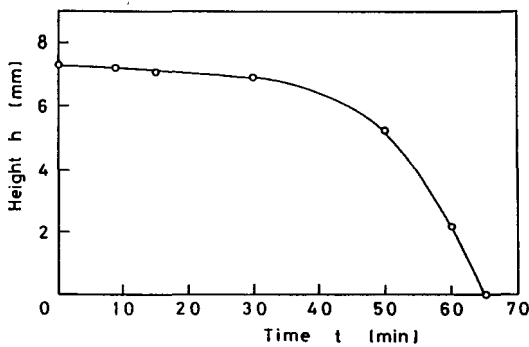

Fig. 6 Decrease in height of frost layer

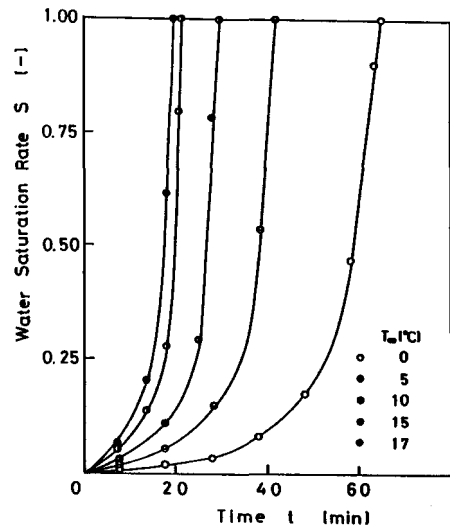

Fig. 7 Relationship between time and water saturation rate

separator. The volumetric water saturation rate is defined as the volume rate of the melting water in the frost layer to the porosity of the frost layer. The experiments are performed under the experimental conditions as shown in table 3. It is known from figure 7 that variety of the volumetric water saturation rate as the elapsed time to the environmental temperature has the same tendency in every melting experiment. In the case of the melting experiment under the condition of $T_{\infty} = 0$ [$^{\circ}\text{C}$], until about forty-five minutes elapse, the part of the frost layer is saturated by the melting water. And the translucent frost layer is formed, the water saturation rate is close to that at starting of the melting experiment. However the frost melting rate increases since the emissivity of the frost layer increases with an increase of the melting water in the defrosting process. Therefore the water saturation rate increases sharply, and then the melting process of the frost layer finishes.

Figure 8 shows the relationship between the environmental temperature and the time taken for the complete melting frost layer.

Table 3 Frosting and defrosting conditions

	Frosting	Defrosting				
Temperature of Cooling Surface T_C [$^{\circ}\text{C}$]	-25	0				
Environmental Temperature T_{∞} [$^{\circ}\text{C}$]	10 ~ 15	0	5	10	15	17
Relative Humidity ψ [%]	60 ~ 70	45 ~ 50				
Frosting Time t_0 [hour]	20	—				
Radiative Heat Flux Q_H [kW/m^2]	—	0.28				

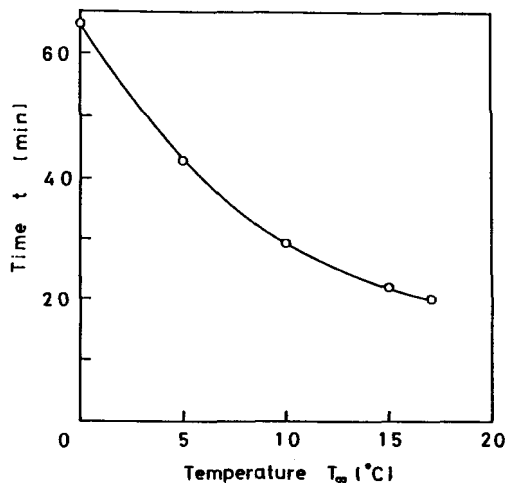

Fig. 8 Variation of environmental temperature with time

It is found in this figure that the time taken for the complete melting frost layer decreases with an increases of the environmental temperature. The difference of the time taken for the complete melting frost layer may depend upon the influence of the radiation and the conduction due to the difference between the frost surface and the environmental temperature.

3.4 Transparency and reflectivity on the frost surface

Figure 9 indicates the mean reflectivity at various times after starting of the defrosting experiment by the radiant heat flux sensor in the condition of the zenith angle at 45 degrees and the directional angle between 0 degrees to 90 degrees. The frosting and defrosting conditions are tabulated in table 4. The radiant heat flux sensor allows of moving at 110mm distance from the center of the copper hemispherically. At the beginning of the melting experiment, the water saturation rate is very small and reflectivity on the frost

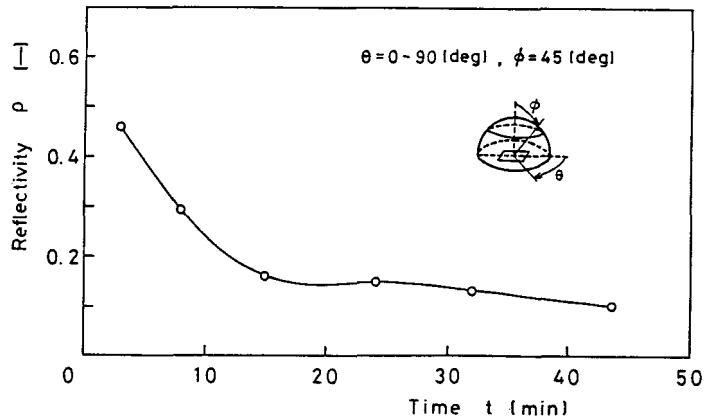

Fig. 9 Variation of reflectivity of frost surface with time

Table 4 Frosting and defrosting conditions

	Frosting	Defrosting
Temperature of Cooling Surface T_C [$^{\circ}\text{C}$]	-20	0
Environmental Temperature T_{∞} [$^{\circ}\text{C}$]	10	0
Relative Humidity ψ [%]	60	50
Frosting Time t_0 [hour]	15	—
Radiative Heat Flux Q_H [kW/m^2]	—	0.28

surface is large because of the roughness of the frost surface. As the time elapses, the reflectivity on the frost surface decreases because the water drops are formed by melting the frost surface, and the penetration of the melting water into the frost surface increases. Thereafter the reflectivity on the frost surface decreases moreover because of the forming of the translucent frost layer. When the whole of the frost layer melts away, the film of the melting water is formed, the reflectivity on the melting water indicates eventually the constant value. The obtained reflectivity of the cooling copper surface is 0.29.

Figure 10 shows the directional reflectivity as the time elapses shown in figure 9. In figure 10 (a) at three minutes elapse, it is found that the directional distribution of the reflectivity on the frost surface is changed against the angle because of the frost

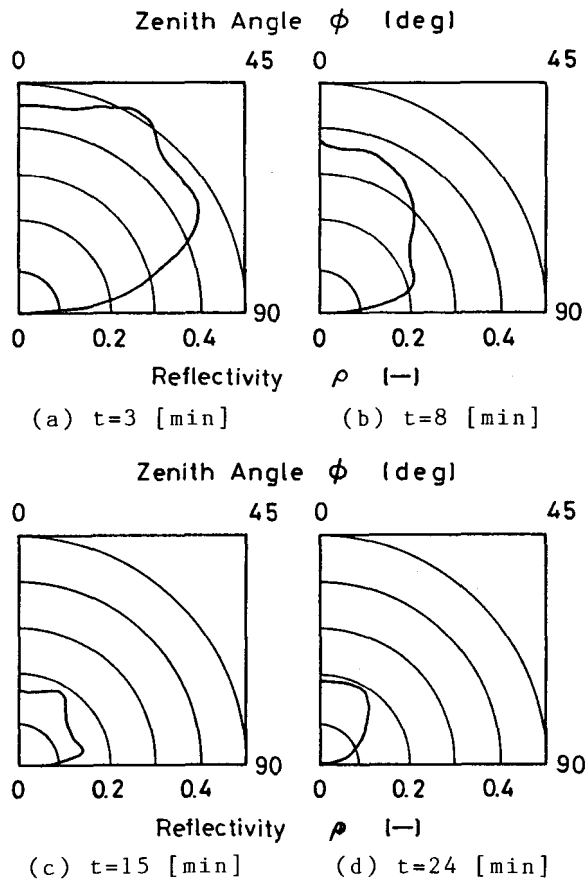

Fig. 10 Variation of directional reflectivity of frost layer with time

surface roughness. At eight minutes elapse, the frost surface is close to diffusely reflecting surface and the directional distribution of the reflectivity on the frost surface becomes small variation against the angle. These differences of reflectivity on the frost surface against the melting time can be explained that the difference of the reflectivity between water and ice is changed since the amount of water droplets on the frost layer are changed by the amount of melting water. Thereafter the variation of directional reflectivity distribution becomes large because the melting water on the frost surface penetrates toward the bottom of the frost layer, and the frost surface changes to the roundish type. Consequently, the porosity of the frost layer is filled with the melting water, and the flat layer of the film consisted of the ice and water is formed. Therefore the directional distribution of the reflectivity on the frost surface would have the tendency of the reflectivity of the cooling copper plate.

Figure 11 shows the transparency of the frost layer with time, which is measured by the radiant heat flux sensor located below the acrylic plate used as a cooling plate during the defrosting experiments. The frosting and defrosting conditions are tabulated in table 5. The transparency of frost layer is defined as the

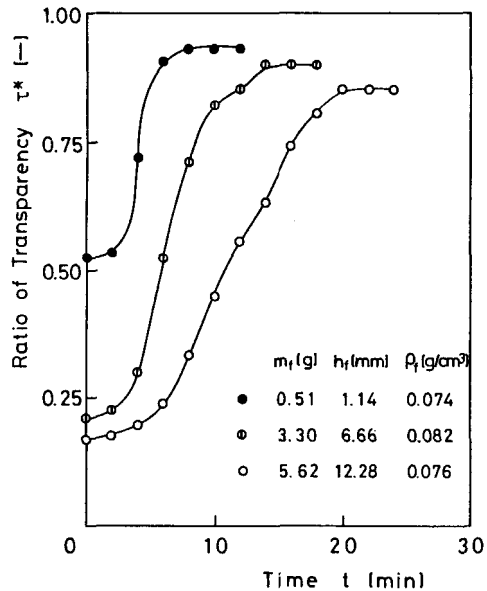

Fig. 11 Relationship between ratio of transparency and time

Table 5 Frosting and defrosting conditions

	Frosting			Defrosting
Temperature of Cooling Surface T_C [$^{\circ}\text{C}$]	20			0
Environmental Temperature T_{∞} [$^{\circ}\text{C}$]	10			0
Relative Humidity ψ [%]	60 ~ 70			50
Frosting Time t_0 [hour]	3	16	25	—
Radiative Heat Flux Q_H [kW/m^2]	—			0.28

ratio of the radiant heat flux penetrated through the frost layer and acrylic plate to that passed through acrylic plate. At the beginning of the melting experiment, the transparency is small. As the time elapses, the transparency and absorptivity of the frost layer increases because the reflectivity on the frost layer is small due to the existing of melting water produced on the frost surface. In the condition of the constant frost density, the greater the height of the frost layer is, the smaller the transparency at the beginning of the experiment becomes, since the reflectivity on the frost surface and absorptivity increases with an increase of the height of the frost layer.

4. Conclusions

The melting process of the frost layer was experimentally investigated. At the beginning in the melting process, the frost melting rate was slow due to the large reflectivity on the frost surface. When the porosity of the frost layer was saturated by the melting water, the frost melting rate increased with an increase of the radiative heat absorption in the frost layer. The reflectivity, the transparency and the directional distribution of the reflectivity on the frost surface during the melting process were clarified in the defrosting experiments.

REFERENCES

- (1) Hayashi, Y., Aoki, K. and Yuhara, H.; "Study of Frost Formation in Forced Convection," *Trans. JSME*, 42-355, pp.885-899(1976)
- (2) Woodside, W.; "Calculation of the Thermal Conductivity of Porous media," *Canadian Journal of Physics*, 36, pp.815-823 (1958)
- (3) Lisovsky, V.M. and Pavlov, B.M.; "Solid Phase Condensation Heat Transfer on a Cold Surface," *Heat Transfer Soviet Research*, 19-1, pp. 18-23 (1987)

- (4) Cremers,C.J. and Mehra,V.K.;"Frost Formation on Vertical Cylinders in Free Convection,"Trans.ASME,Journal of Heat Transfer,104,pp.3-7 (1982)
- (5) White,J.E. and Cremers,C.J.,"Prediction of Growth Parameters of Frost Deposits in Forced Convection,"Trans.ASME, Journal of Heat Transfer,103,pp.3-6 (1981)
- (6) Chen,M.M. and Rosenow,W.,"Heat and Mass and Momentum Transfer Inside Frost Tubes. Experiment and Theory,"Trans.ASME,Journal of Heat Transfer,86,pp.334-340 (1964)
- (7) Katsuta,K. and Ishihara,I.,"Heat Transfer by Natural Convection with Simultaneous Frosting on Horizontal Cylinders in a Vertical Array,"Refrigeration,54,pp.229-238 (1983)
- (8) Katsuta,K.,Ishihara,I. and Mukai,T.,"An Analytical Study of Defrosting by the Ambient Air under Natural Convection," Refrigeration,58-669,pp.645-650 (1983)
- (9) Inaba,H., Otake,H. and Fukuda,T.,"A Study of Flow Characteristics of Melting Water Retained in a Snow Layer,"Preprints of the JSME, 882-2,pp.60-61 (1988)
- (10) Inaba,H. and Otake,H.,"Fundamental Study on Measurement of Water Saturation Rate in a Snow layer,"Trans.JSME,56-526,pp.1796-1800 (1990)
- (11) Inaba,H., Otake,H. and Nozu,S.,"A Study of Snow Melting Mechanism by Solar Radiative Absorption Material," Preprints of ISTP , 4-2, pp.484-495 (1991)