

Design of an Adaptive Observer to Estimate Unknown Periodical Disturbances

Valeri T. KROUMOV* Akira INOUE* Shiro MASUDA*

(Received January 29 , 1993)

SYNOPSIS

This report deals with the problem of designing an adaptive observer for estimating unknown periodical disturbances. This is very practical problem because in the area of control of servomechanisms such disturbances are always encountered. When the disturbance cannot be directly measured or eliminated at the source it is necessary to perform a prediction. When a periodical disturbance is present the frequencies appear as unknown parameters and they have to be identified. In order to identify the unknown parameters, it is necessary to transform the composite system model, which contains the models of the controlled system and the disturbances, into observable canonical form. In addition, an inverse transformation is required to calculate the estimates of the present disturbances.

In this report, firstly, a review of an adaptive observer for estimation of unknown periodical disturbances is presented. Later a calculation of the disturbance estimate is derived using the algebraic programming system REDUCE. The proposed method here allows to perform all the necessary transformations and to obtain the disturbance estimation without using the transformation matrix. The calculations of these transformations are complicated and, hitherto, there is no simple method to perform them. The results of disturbance estimation are illustrated by two examples.

1 Introduction

The nature of the present disturbances is directly connected with the quality of regulation in the process of control. The estimation of the disturbances allows their reduction and consequently

*Department of Information Technology

improvement of the regulation characteristics of the system. One of the serious problems in obtaining the characteristics of the present disturbances is that very often they are not directly measurable. Therefore the disturbance have to be modeled in a certain way, and their estimated values can be used for further reduction.

When the disturbance can be represented by a polynomial model the estimation can be done by using Luenberger type state observer. If the disturbances has a periodical character, as it is in the servomechanical systems, the polynomial model does not allow to perform good estimation [1]. A sinusoidal model is applied instead. However, in the latter frequencies appear as unknown parameters and they have to be identified. This requires application of an adaptive observer. In order to identify the unknown parameters, it is necessary to transform the composite system model, which contains the models of the controlled system and the disturbances, into observable canonical form. In addition, the calculation of the estimates of the present disturbances requires an inverse transformation.

This report deals with the problem of estimation of the characteristics of unknown periodical disturbances using an adaptive observer. Firstly, a review of an adaptive observer for estimation of unknown periodical disturbances is presented [1]. Later a calculation of the disturbance estimate is derived using the algebraic programming system REDUCE. The method proposed here allows to perform the transformation to canonical form and to obtain the estimate of the unknown disturbance without referring to the transformation matrix. The calculation of the latter and its inverse is a tedious procedure especially in the case of systems of high order.

2 Problem Statement

Consider a linear time-invariant, fully observable, single-input single-output (SISO) system of order n with inaccessible states. Further, consider that an unknown sinusoidal disturbance influences the system. The system is described in observable canonical form:

$$\begin{aligned} \frac{d}{dt} \mathbf{x}_p(t) &= A_p \mathbf{x}_p(t) + \mathbf{b}_p u(t) + \mathbf{f} d(t) \\ y(t) &= \mathbf{c}_p^T \mathbf{x}(t), \end{aligned} \quad (1)$$

where $\mathbf{x}_p^{(n \times 1)}$ is the state vector, and $A_p^{(n \times n)}$, $\mathbf{b}_p^{(n \times 1)}$, $\mathbf{c}_p^{(n \times 1)}$, and $\mathbf{f}^{(n \times 1)}$ are coefficient matrices:

$$A = \begin{bmatrix} 1 & \dots & 0 \\ \vdots & \ddots & \vdots \\ -\mathbf{a}_p & & 1 \\ 0 & \dots & 0 \end{bmatrix}, \quad \mathbf{a}_p = \begin{bmatrix} a_{p1} \\ \vdots \\ a_{pn} \end{bmatrix}, \quad \mathbf{b}_p = \begin{bmatrix} b_{p1} \\ \vdots \\ b_{pn} \end{bmatrix}, \quad \mathbf{c}_p = \begin{bmatrix} 1 \\ 0 \\ \vdots \\ 0 \end{bmatrix}, \quad \mathbf{x}_p = \begin{bmatrix} x_{p1} \\ \vdots \\ x_{pn} \end{bmatrix}, \quad \mathbf{f} = \begin{bmatrix} f_1 \\ \vdots \\ f_n \end{bmatrix}$$

The disturbance $d(t)$ is described as a sinusoidal wave with unknown parameters:

$$d(t) = a \sin(\omega t + \nu) \quad (2)$$

where a , ω , and ν are the amplitude, the angular frequency, and the phase, respectively.

The problem to be solved is to estimate the unknown disturbance using only the measurable input and output of the above described system.

The disturbance is regarded as a response of dynamic system with zero input but nonzero initial conditions. Its state space model is given as:

$$\begin{aligned} \frac{d}{dt} \boldsymbol{\eta}(t) &= D \boldsymbol{\eta} \\ d(t) &= \mathbf{h}^T \boldsymbol{\eta} \end{aligned}, \quad D = \begin{bmatrix} 0 & \omega \\ -\omega & 0 \end{bmatrix}, \quad \mathbf{h} = \begin{bmatrix} 1 \\ 0 \end{bmatrix}, \quad \boldsymbol{\eta} = \begin{bmatrix} \eta_1 \\ \eta_2 \end{bmatrix}, \quad (3)$$

where ω is unknown frequency and it is assumed that $\boldsymbol{\eta}$ cannot be measured. By introducing the augmented state vector:

$$\mathbf{x}(t)^T = \begin{bmatrix} \mathbf{x}_p(t)^T & \boldsymbol{\eta}(t)^T \end{bmatrix}$$

the system can be described by:

$$\begin{aligned} \frac{d}{dt} \begin{bmatrix} \mathbf{x}_p(t) \\ \boldsymbol{\eta}(t) \end{bmatrix} &= \begin{bmatrix} A_p & \mathbf{f} \mathbf{h}^T \\ \mathbf{0} & D \end{bmatrix} \begin{bmatrix} \mathbf{x}_p(t) \\ \boldsymbol{\eta}(t) \end{bmatrix} + \begin{bmatrix} \mathbf{b}_p \\ \mathbf{0} \end{bmatrix} u(t) = A \mathbf{x}(t) + \mathbf{b} u(t) \\ y(t) &= \begin{bmatrix} \mathbf{c}_p^T & \mathbf{0}^T \end{bmatrix} \begin{bmatrix} \mathbf{x}_p(t) \\ \boldsymbol{\eta}(t) \end{bmatrix} = \mathbf{c}^T \mathbf{x}(t). \end{aligned} \quad (4)$$

The necessary and sufficient conditions for observability of the composite system (4) are given in [1].

3 Identification of the Disturbance Parameters

To identify the frequency parameters an observer according to [4] is derived. First, we transform the augmented system (4) in observable canonical form:

$$\begin{aligned} \frac{d}{dt} \mathbf{x}_c(t) &= A_c \mathbf{x}_c(t) + \mathbf{b}_c u(t) \\ y(t) &= \mathbf{c}_c^T \mathbf{x}_c(t), \end{aligned} \quad (5)$$

where

$$A_c = TAT^{-1} = \begin{bmatrix} & 1 & \dots & 0 \\ & \vdots & \ddots & \vdots \\ -\mathbf{a}_c & & & \\ & 0 & \dots & 1 \\ & 0 & \dots & 0 \end{bmatrix}, \quad \mathbf{a}_c = \begin{bmatrix} a_{c1} \\ \vdots \\ a_{cm} \end{bmatrix}, \quad \mathbf{b}_c = T\mathbf{b} = \begin{bmatrix} b_{c1} \\ \vdots \\ b_{cm} \end{bmatrix}, \quad (6)$$

$$\mathbf{c}_c^T = \mathbf{c}^T T^{-1} = \begin{bmatrix} 1 & 0 & \dots & 0 \end{bmatrix}, \quad m = n + 2$$

$$\mathbf{x}_c(t) = T\mathbf{x}(t), \text{ and } T \text{ is the transformation matrix.} \quad (7)$$

The elements of the vectors \mathbf{a}_c , \mathbf{b}_c can be obtained by direct calculations from \mathbf{a}_p and \mathbf{b}_p without referring to the transformation matrix T [3]:

$$\mathbf{a}_c = \Delta \mathbf{a}_p + \mathbf{q} \quad (8)$$

$$\mathbf{b}_c = \Delta \mathbf{b}_p,$$

where the matrix Δ and the vector \mathbf{q} have the following forms:

$$\Delta = \begin{bmatrix} 1 & 0 & \dots & 0 \\ \mathbf{p} & 1 & \dots & 0 \\ \vdots & \ddots & \ddots & \vdots \\ 0 & \dots & 0 & \mathbf{p} \end{bmatrix}, \quad \mathbf{p} = \begin{bmatrix} 0 \\ \theta \end{bmatrix}, \quad \mathbf{q} = \begin{bmatrix} \mathbf{p} \\ 0 \\ \vdots \\ 0 \end{bmatrix}, \quad \theta = \omega^2, \quad (9)$$

and Δ and \mathbf{q} have dimensions $m \times n$, and $m \times 1$ respectively, and θ represents the unknown frequency.

In order to construct the observer, the plant is parametrized in the form:

$$\frac{d}{dt} \mathbf{x}_c(t) = K \mathbf{x}_c(t) + \boldsymbol{\varphi} y(t) + \mathbf{b}_c u(t), \quad \text{where} \quad (10)$$

$$K = \begin{bmatrix} -k_1 & 1 & \dots & 0 \\ -k_2 & & \ddots & \\ \vdots & 0 & \dots & 1 \\ -k_m & 0 & \dots & 0 \end{bmatrix}, \quad \boldsymbol{\varphi} = \begin{bmatrix} k_1 - a_{c1} \\ k_2 - a_{c2} \\ \vdots \\ k_m - a_{cm} \end{bmatrix}, \quad m = n + 2,$$

and the vector $\mathbf{k}^T = \begin{bmatrix} k_1 & k_2 & \dots & k_m \end{bmatrix}$ is chosen so that the matrix K is asymptotically stable.

The unknown frequency ω can be identified from the measured input and output of the system.

Define $2m$ vector variables:

$$\frac{d}{dt} \mathbf{z}_{11}^T(t) = \mathbf{z}_{11}^T(t)K + \mathbf{c}_c^T y(t) \quad \mathbf{z}_{11}(0) = 0 \quad (11)$$

$$\frac{d}{dt} \mathbf{z}_{21}^T(t) = \mathbf{z}_{21}^T(t)K + \mathbf{c}_c^T u(t) \quad \mathbf{z}_{21}(0) = 0,$$

where \mathbf{z}_{11} and \mathbf{z}_{21} are the first rows of the matrices

$$Z_1 = [z_{1,ij}] = \int_0^t e^{K(t-\tau)} y(\tau) d\tau, \quad Z_2 = [z_{2,ij}] = \int_0^t e^{K(t-\tau)} u(\tau) d\tau, \quad i, j = 1, \dots, m \quad (12)$$

respectively. The estimates of the output and the states can be written as:

$$\begin{aligned} \hat{y}(t) &= \hat{x}_{c_1} = z_{11}^T \hat{\varphi} + z_{21}^T \hat{b}_c \\ &= z_{111}(k_1 - \hat{a}_{c_1}) + \dots + z_{11m}(k_m - \hat{a}_{c_m}) + z_{211} \hat{b}_{c_1} + z_{212} \hat{b}_{c_2} + \dots + z_{21m} \hat{b}_{c_m} \end{aligned} \quad (13)$$

$$\begin{aligned} \hat{x}_{c_i}(t) &= z_{1i}^T \hat{\varphi} + z_{2i}^T \hat{b}_c \\ &= z_{1i1}(k_1 - \hat{a}_{c_1}) + \dots + z_{1im}(k_m - \hat{a}_{c_m}) + z_{2i1} \hat{b}_{c_1} + z_{2i2} \hat{b}_{c_2} + \dots + z_{2im} \hat{b}_{c_m}, \quad i = 2, \dots, m \end{aligned} \quad (14)$$

The vectors \hat{a}_c and \hat{b}_c are obtained after substituting the identified parameter $\hat{\theta}$ in eq. (8). After separation of the members containing $\hat{\theta}$ and rearranging, the last two equations can be rewritten as follows:

$$\hat{y}(t) = l_{01} + l_{11} \hat{\theta}, \quad (15)$$

$$\hat{x}_{c_i}(t) = l_{0i} + l_{1i} \hat{\theta}, \quad i = 2, \dots, m, \quad (16)$$

where l_{01} and l_{0i} are sums of terms in (15) and (16) which do not include $\hat{\theta}$, and l_{11} and l_{1i} are sums of coefficients of the terms in (15) and (16) which include $\hat{\theta}$.

To identify the parameter $\theta = \omega^2$ a suitable parameter adjusting law can be applied. One example is the weighted least squares method, which for continuous-time systems has the form:

$$\begin{aligned} \frac{d\hat{\theta}(t)}{dt} &= -R^{-1}(t)l_{11}(t)[y(t) - \hat{y}(t)] \\ \frac{dR(t)}{dt} &= -\alpha R(t) + l_{11}(t)l_{11}^T(t) \\ \hat{y}(t) &= l_{01}(t) + l_{11}(t)\hat{\theta}(t). \end{aligned} \quad (17)$$

In the discrete-time the weighted least squares looks like:

$$\begin{aligned} \hat{\theta}(k+1) &= \hat{\theta}(k) - \frac{R^{-1}(k)l_{11}(k+1)}{\alpha + l_{11}^T(k+1)R^{-1}(k)l_{11}(k+1)}(y(k+1) - \hat{y}(k+1)) \\ R^{-1}(k+1) &= \frac{1}{\alpha} \left(R^{-1}(k) - \frac{R^{-1}(k)l_{11}(k+1)l_{11}^T(k+1)R^{-1}(k)}{\alpha + l_{11}^T(k+1)R^{-1}(k)l_{11}(k+1)} \right) \\ \hat{y}(k+1) &= l_{01}(k+1) + l_{11}^T(k+1)\hat{\theta}(k), \end{aligned} \quad (18)$$

where $0 < \alpha \leq 1$ is the weighting factor, used for data discrimination if necessary, and $R(\cdot)$ is a symmetric positive definite time-varying gain matrix of dimension 1×1 .

From the arguments used in this section it directly follows that $\lim_{t \rightarrow \infty} (\hat{\theta}(t) - \theta) = 0$.

Order of (1)	Disturbance estimate, $\hat{d} = \frac{N}{D}$
2	$N = -\omega^2 f_2 x_{e_1} + \omega^2 f_1 x_{e_2} + f_2 x_{e_3} - f_1 x_{e_4}$ $D = \omega^2 f_1^2 + f_2^2$
3	$N = -\omega^4 f_2 x_{e_1} + (\omega^4 f_1 + \omega^2 f_3) x_{e_2} + \omega^2 f_2 x_{e_3} - \omega^4 f_1 x_{e_4} - f_2 x_{e_5}$ $D = f_1(\omega^4 f_1 - \omega^2 f_3) + \omega^2 f_2^2 + f_3(-\omega^2 f_1 + f_3)$
4	$N = [f_4 - f_2(-\hat{\omega}^2)][(-\hat{\omega}^2)^2 \hat{x}_{e_1}(t) - (-\hat{\omega}^2) \hat{x}_{e_3}(t) + \hat{x}_{e_5}(t)]$ $+ [f_1(-\hat{\omega}^2) - f_3][(-\hat{\omega}^2)^2 \hat{x}_{e_2}(t) - (-\hat{\omega}^2) \hat{x}_{e_4}(t) + \hat{x}_{e_6}(t)]$ $D = -f_1[f_1(-\hat{\omega}^2) + 2f_3](-\hat{\omega}^2)^2$ $+ f_2[f_2(-\hat{\omega}^2) + 2f_4](-\hat{\omega}^2) - f_3^2(-\hat{\omega}^2) + f_4^2$
5	$N = -[f_2(-\hat{\omega}^2) + f_4](-\hat{\omega}^2)^3 x_{e_1} + [f_1(-\hat{\omega}^2)^2 + f_3(-\hat{\omega}^2) + f_5](-\hat{\omega}^2)^2 x_{e_2}$ $- [f_2(-\hat{\omega}^2) + f_4](-\hat{\omega}^2)^2 x_{e_3} + [f_1(-\hat{\omega}^2)^2 + f_3(-\hat{\omega}^2) + f_5](-\hat{\omega}^2) x_{e_4}$ $- [f_2(-\hat{\omega}^2) + f_4](-\hat{\omega}^2) x_{e_5} + [f_1(-\hat{\omega}^2)^2 + f_3(-\hat{\omega}^2) + f_5] x_{e_6} - [f_2(-\hat{\omega}^2) + f_4] x_{e_7}$ $D = (-1)\{f_1[f_1(-\hat{\omega}^2)^2 + 2f_3(-\hat{\omega}^2) + 2f_5](-\hat{\omega}^2)^2$ $+ f_2[f_2(-\hat{\omega}^2)^2 + 2f_4(-\hat{\omega}^2)](-\hat{\omega}^2)$ $- f_3[f_3(-\hat{\omega}^2) + 2f_5](-\hat{\omega}^2) + f_4^2(-\hat{\omega}^2) - f_5^2\}$

Table 1: Disturbance estimate calculations

4 Disturbance Estimation

In this section, using the identified frequency, we derive the estimate of the unknown disturbance. From the discussion in the previous section, for the estimate of the disturbance it can be written:

$$\hat{d}(t) = \mathbf{h}_c^T T^{-1} \hat{\mathbf{x}}_c(t), \quad \mathbf{h}_c^T = \begin{bmatrix} \mathbf{0}^T & \mathbf{h}^T \end{bmatrix} \quad (19)$$

Note that up to the end of the previous section all the transformations were done without referring to the transformation matrix T . Now we are going to introduce a calculation which allows to obtain the estimate of the unknown disturbance directly from the identified state $\hat{\mathbf{x}}_c$ and parameter $\hat{\theta}$. The proposed below calculation was obtained using the algebraic programming system REDUCE [5]. Starting with a system of second order we have calculated consequently the disturbance estimate for systems of higher order (see. Table 1). By induction, the results of the calculations were used to find an expression for calculation of the disturbance estimate for the general case, i.e. n -th order SISO system:

Theorem 4.1 [2] For a linear time-invariant, single-input single-output system (1), with a presence of single sinusoidal wave disturbance (2) the estimate of latter is given as follows:

$$\hat{d}(t) = \frac{AC + BD}{F}, \text{ where} \quad (20)$$

$$A = (-1)^n [f_2(-\hat{\omega}^2)^{\frac{n+d}{2}-1} + f_4(-\hat{\omega}^2)^{\frac{n+d}{2}-2} + \dots + f_{n-2+d}(-\hat{\omega}^2) + f_{n+d}] \quad (21)$$

$$B = (-1)^{n+1} [f_1(-\hat{\omega}^2)^{\frac{n-d}{2}-1} + f_3(-\hat{\omega}^2)^{\frac{n-d}{2}-2} + \dots + f_{n-3-d}(-\hat{\omega}^2) + f_{n-1-d}] \quad (22)$$

$$C = (-\hat{\omega}^2)^{\frac{n-d}{2}} \hat{x}_{c_1} + (-\hat{\omega}^2)^{\frac{n-d}{2}-1} \hat{x}_{c_3} + \dots + (-\hat{\omega}^2) \hat{x}_{c_{n-1-d}} + \hat{x}_{c_{n+1-d}} \quad (23)$$

$$D = (-\hat{\omega}^2)^{\frac{n+d}{2}} \hat{x}_{c_2} + (-\hat{\omega}^2)^{\frac{n+d}{2}-1} \hat{x}_{c_4} + \dots + (-\hat{\omega}^2) \hat{x}_{c_{n+d}} + \hat{x}_{c_{n+2+d}} \quad (24)$$

$$\begin{aligned} F = & (-1)^n \{-f_1[f_1(-\hat{\omega}^2)^{n-1} + 2f_3(-\hat{\omega}^2)^{n-2} + 2f_5(-\hat{\omega}^2)^{n-3} + \dots] \\ & + f_2[f_2(-\hat{\omega}^2)^{n-2} + 2f_4(-\hat{\omega}^2)^{n-3} + 2f_6(-\hat{\omega}^2)^{n-4} + \dots] \\ & - f_3[f_3(-\hat{\omega}^2)^{n-3} + 2f_5(-\hat{\omega}^2)^{n-4} + 2f_7(-\hat{\omega}^2)^{n-5} + \dots] \\ & + f_4[f_4(-\hat{\omega}^2)^{n-4} + 2f_6(-\hat{\omega}^2)^{n-5} + 2f_8(-\hat{\omega}^2)^{n-6} + \dots] \\ & \vdots \\ & - f_{n-2}[f_{n-2}(-\hat{\omega}^2)^2 + 2f_n(-\hat{\omega}^2)] + f_{n-1}^2(-\hat{\omega}^2) + f_n^2\} \end{aligned} \quad (25)$$

where $d = -1$, when the order of the system is odd number, and $d = 0$ when the order is an even number.

Proof. While the reader is referred to [6] for detailed proof the following comments may be used as a guideline. It can be seen that the estimate of the disturbance $\hat{d}(t)$ is obtained from the row before last in equation (19). More clearly this can be seen from eq. (4) in which the model of the disturbance well stands out. Rewrite the expression (20) separating the state-space variables vector, i.e.

$$\hat{d}(t) = \begin{bmatrix} \beta_1 & \beta_2 & \dots & \beta_{n+2} \end{bmatrix} \begin{bmatrix} \hat{x}_{c_1}(t) \\ \hat{x}_{c_2}(t) \\ \vdots \\ \hat{x}_{c_{n+2}} \end{bmatrix} = \beta \hat{x}_c(t). \quad (26)$$

The product of β and the transformation matrix T is a unit vector with 1 in position $n + 1$, i.e. the position before last. The proof of this can be easily derived by analyzing the structure of the transformation matrix as it is done in [6]. First, the product of β and an $(n+2) \times n$ matrix composed

of the first n columns of T is analysed. After this the product of β and the last two ($n + 1$ and $n + 2$) columns of T is analysed. Only the product of β and $n + 1$ column of T is equal to 1. The rest are zero. Hence the proof is established.

It can be seen from the above discussion that the disturbance estimation observer is composed of filter variables (11), parameter adjusting law (17) or (18), and disturbance estimation equation (20).

5 Examples

5.1 Simulation Example

Consider a 4-th order dynamic system:

$$Y(s) = \frac{b_{p1}s^3 + b_{p2}s^2 + b_{p3}s + b_{p4}}{s^4 + a_{p1}s^3 + a_{p2}s^2 + a_{p3}s + a_{p4}}U(s) + \frac{f_1s^3 + f_2s^2 + f_3s + f_4}{s^4 + a_{p1}s^3 + a_{p2}s^2 + a_{p3}s + a_{p4}}D(s)$$

with an unknown disturbance as in eq. (3). Suppose that $d(t)$ changes its amplitude, phase, and frequency at a certain moment. Assuming that only the input $u(t)$ and the output $y(t)$ are accessible we identify the unknown frequency ω and the disturbance $d(t)$.

The canonical state-space description of the above system applying (8) and (9) is:

$$\frac{d}{dt} \begin{bmatrix} x_{c1}(t) \\ x_{c2}(t) \\ x_{c3}(t) \\ x_{c4}(t) \\ x_{c5}(t) \\ x_{c6}(t) \end{bmatrix} = \begin{bmatrix} -a_{p1} & 1 & 0 & 0 & 0 & 0 \\ -(a_{p2} + \omega^2) & 0 & 1 & 0 & 0 & 0 \\ -(a_{p1}\omega^2 + a_{p3}) & 0 & 0 & 1 & 0 & 0 \\ -(a_{p2}\omega^2 + a_{p4}) & 0 & 0 & 0 & 1 & 0 \\ -a_{p3}\omega^2 & 0 & 0 & 0 & 0 & 1 \\ -a_{p4}\omega^2 & 0 & 0 & 0 & 0 & 0 \end{bmatrix} \begin{bmatrix} x_{c1}(t) \\ x_{c2}(t) \\ x_{c3}(t) \\ x_{c4}(t) \\ x_{c5}(t) \\ x_{c6}(t) \end{bmatrix} + \begin{bmatrix} b_{p1} \\ b_{p2} \\ b_{p1}\omega^2 + b_{p3} \\ b_{p2}\omega^2 + b_{p4} \\ b_{p3}\omega^2 \\ b_{p4}\omega^2 \end{bmatrix} u(t)$$

$$y(t) = \begin{bmatrix} 1 & 0 & 0 & 0 & 0 & 0 \end{bmatrix} \mathbf{x}_c(t)$$

For the disturbance estimate we write (see (20)-(25)):

$$\hat{d}(t) = \frac{(f_4 - f_2\hat{\theta}(t))(\hat{\theta}(t)^2\hat{x}_{c1}(t) - \hat{\theta}(t)\hat{x}_{c3}(t) + \hat{x}_{c5}(t)) + (f_1\hat{\theta}(t) - f_3)(\hat{\theta}(t)^2\hat{x}_{c2}(t) - \hat{\theta}(t)\hat{x}_{c4}(t) + \hat{x}_{c6}(t))}{-f_1[f_1(-\hat{\theta}(t)) + 2f_3]\hat{\theta}(t)^2 + f_2[f_2(-\hat{\theta}(t)) + 2f_4](-\hat{\theta}(t)) - f_3^2(-\hat{\theta}(t)) + f_4^2}$$

The conditions for the computer simulation are:

- Sampling period: $t_k = 0.03s$
- Number of the sampling periods: 1165

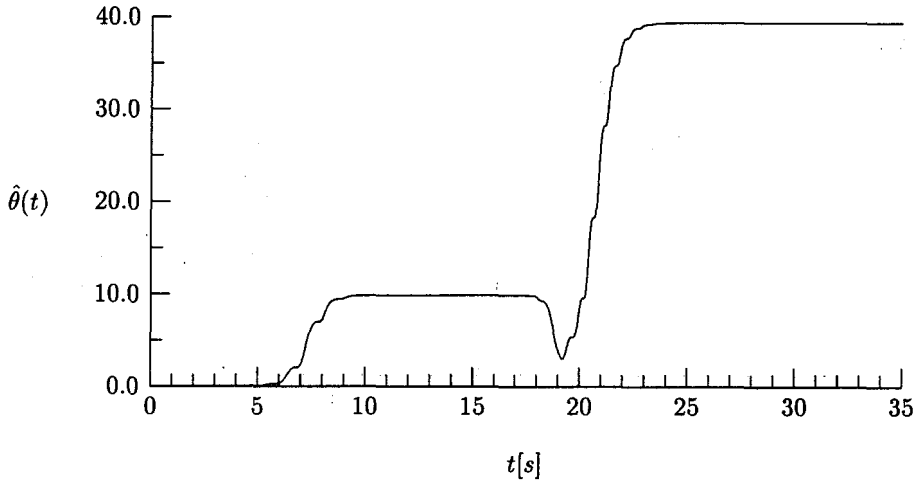
Figure 1: Identified frequency $\hat{\theta}(t)$ — simulation

- Plant coefficients: $a_{p1} = 10.0$, $a_{p2} = 35.0$, $a_{p3} = 50.0$, $a_{p4} = 24.0$;
 $b_{p1} = b_{p2} = b_{p3} = 0$, $b_{p4} = 20.0$, $f_1 = f_2 = f_3 = 0$, $f_4 = 20.0$
- Filter poles: -5.0 , -5.2 , -5.4 , -5.6 , -5.8 , -6.0
- Filter coefficients:

$$k = \begin{bmatrix} k_1 \\ k_2 \\ k_3 \\ k_4 \\ k_5 \\ k_6 \end{bmatrix} = \begin{bmatrix} 33.00 \\ 453.40 \\ 3319.80 \\ 13662.44 \\ 29964.42 \\ 27361.15 \end{bmatrix}$$

- Parameter adjusting law: weighted least squares as in eq. (18) with forgetting factor: $\alpha = 0.935$
- Disturbance: $0 \leq t_k \leq 17.5s \rightarrow d = 3 \sin(\pi t_k + \frac{\pi}{6})$
 $17.5 < t_k < 35s \rightarrow d = \sin(2\pi t_k + \frac{\pi}{4})$

The identified unknown parameter $\hat{\theta}$ and estimated disturbance are shown on Fig. 1 and Fig. 2 respectively. It is seen that the identified parameter $\hat{\theta}$ and the estimate of disturbance well follow the true values despite of the parameters change.

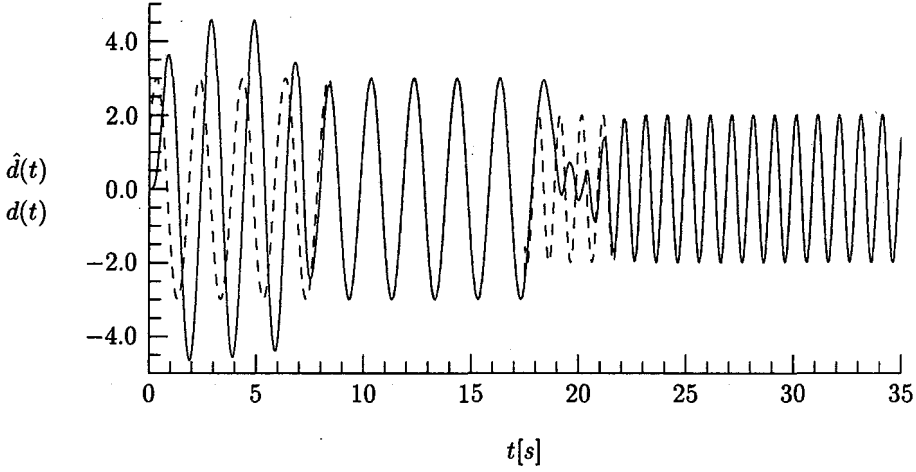

Figure 2: Disturbance estimate (solid line) and input disturbance (dashed line) — simulation

5.2 Experimental Example

The system used in this example is a direct drive (DD) motor (DMB1030—Yokogawa Precision) connected to an amplifier. There is an rotary encoder integrated in the motor's body which produces 655360 p/rev. The input of the system is the amplifier input torque voltage, and the output is the angular position.

The source of the disturbance is the gravity force of an arm and a load attached to the shaft of the motor (Fig. 3). The system is described by the following equation:

$$\ddot{y}(t) = -a_{p1}\dot{y}(t) - a_{p2}y(t) + a_{p3}\text{sgn}y + b_{p1}(u(y) + d(t)), \quad (27)$$

where a_{p1} is the viscous frictional coefficient, a_{p2} is the static friction, and a_{p3} is the Coulomb friction coefficient. The constant b_{p1} has a direct relation to the inertia of the mechanical system.

The augmented system is 4-th order, and its description in canonical observable form, obtained through equations (8) and (9), is:

$$\begin{bmatrix} \dot{x}_{c1}(t) \\ \dot{x}_{c2}(t) \\ \dot{x}_{c3}(t) \\ \dot{x}_{c4}(t) \end{bmatrix} = \begin{bmatrix} -a_{p1} & 1 & 0 & 0 \\ -(a_{p2} + \omega^2) & 0 & 1 & 0 \\ -a_{p1}\omega^2 & 0 & 0 & 1 \\ -a_{p2}\omega^2 & 0 & 0 & 0 \end{bmatrix} \begin{bmatrix} x_{c1}(t) \\ x_{c2}(t) \\ x_{c3}(t) \\ x_{c4}(t) \end{bmatrix} + \begin{bmatrix} 0 \\ 1 \\ 0 \\ \omega^2 \end{bmatrix} (b_{p1}u(t) + a_{p3}\text{sgn}y(t)) \quad (28)$$

$$y(t) = \begin{bmatrix} 1 & 0 & 0 & 0 \end{bmatrix} \mathbf{x}(t)$$

Again, as in the previous example, from eq. (20)–(25) the disturbance estimate can be described by the following equation:

$$\hat{d}(t) = \frac{f_2[\hat{x}_{c3} + \hat{x}_{c1}(-\hat{\omega}^2)] + f_1[\hat{x}_{c4} + \hat{x}_{c2}(-\hat{\omega}^2)]}{f_2^2 + f_1^2(-\hat{\omega}^2)}$$

The conditions under which the experiment was performed are:

- Sampling period: $T_s = 300\mu s$
- Number of the sampling periods: 12288
- Plant coefficients: $a_{p1} = 1.07$, $a_{p2} = 0.03$, $a_{p3} = 179000.0$
 $b_{p1} = 420736.0$; $f_1 = 0$, $f_2 = b_{p1}$
- Filter poles: $-10.0, -12.0, -14.0, -16.0$
- Filter coefficients:

$$\mathbf{k} = \begin{bmatrix} k_1 \\ k_2 \\ k_3 \\ k_4 \end{bmatrix} = \begin{bmatrix} 52.00 \\ 1004.00 \\ 8528.80 \\ 26880.00 \end{bmatrix}$$

- Parameter adjusting law: weighted least squares as in eq. (18) with forgetting factor: $\alpha = 0.9953$

The identified frequency $\hat{\omega}(t)$ and estimated disturbance are shown on Fig. 4. The disturbance has more complicated form than sinusoidal one, because, due to the load, the angle velocity changes its value. The load gravity force reduces the velocity when the rotation is performed from the lowest point to the highest one, and vice-versa, the velocity increases when the gravity force vector has the same sign with the rotation motion. Because of this the identified frequency $\hat{\omega}$ changes its value from $6.5rad/s$ to $9.5rad/s$ but the average $\hat{\omega}_{av} = 8rad/s$ is approximately equal to the velocity of \hat{d} .

6 Conclusions

It has been shown in this report the applicability of the adaptive observer proposed in [1]. In addition an expression for obtaining the estimate of unknown sinusoidal wave disturbance was derived. The main advantage of the proposed here method is that all the necessary calculations are performed without directly referring to the transformation matrix T . Through the examples in the previous section it was shown that the proposed observer can be used for the estimation of unknown sinusoidal disturbance quite effectively.

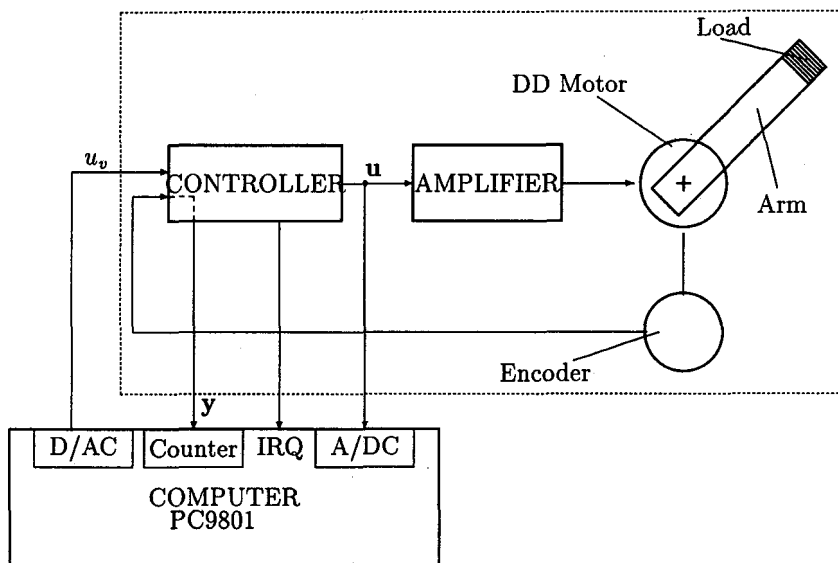
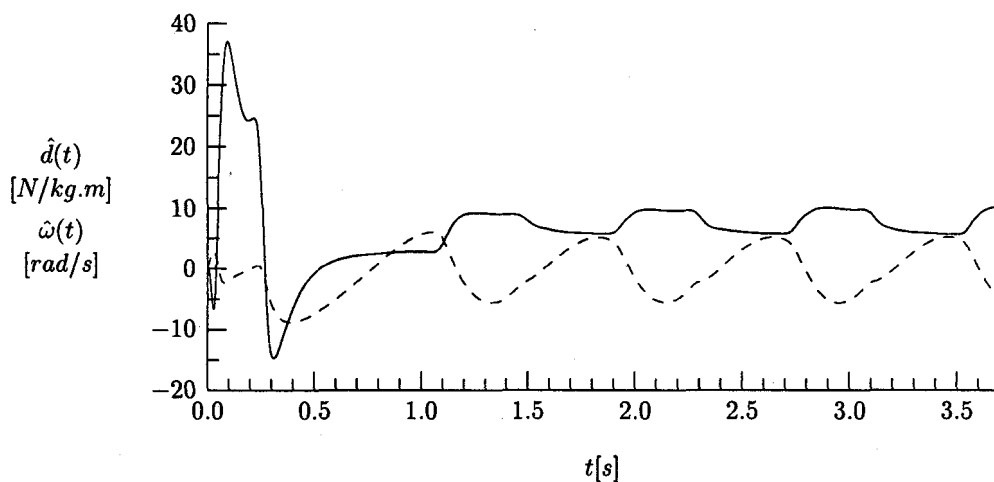

Figure 3: Simplified Diagram of the Experimental System

Figure 4: Identified $\hat{\omega}$ (solid line) and estimated disturbance \hat{d} (dashed line) — experiment

References

- [1] Inoue, A., Sugimoto, K., Masuda, S., A Design of an Adaptive Observer to Estimate Periodic Unknown Disturbance, *Transaction of the Institute of Systems, Control and Information Engineers, Japan, Vol.4, No.6, pp216-225(1991)*
- [2] Kroumov, V., Inoue, A., Masuda, S., Design of an Adaptive Observer to Estimate Unknown Periodical Disturbance, *Proceedings of the 36th Annual Conference of the Institute of System, Control and Information Engineers, ISCIE (May 20-22, 1992)*
- [3] Iwai, Z., Mano, K., Inada, T., An Adaptive Observer for Single-input Single-output Linear Systems with Inaccessible Input, *Int. J. Contr, Vol.32, No. 1, pp. 159-74 (1980)*
- [4] Kreisselmeier, G., Adaptive Observers with Exponential Rate of Convergence, *IEEE Trans.AC, Vol. AC-22, No.1, pp.2-8(1977)*
- [5] Hearn, A.C., REDUCE—User's Manual, Ver. 3.4, *RAND, S.Monica, CA(1991)*
- [6] Murakami S. Adaptive observer design using mathematical programming language, *Dipl. thesis, Dept. of Information Technology, Fac. of Engineering, Okayama Univ., (1992)*